

# Optical Metrology

Lecture 3: Basic Optical Principles and Imaging Systems

# Optical Metrology History

Vision-Based Metrology refers to the technology using optical sensors and digital image processing hardware and software to:

- Identify
- Guide
- Inspect
- Measure objects

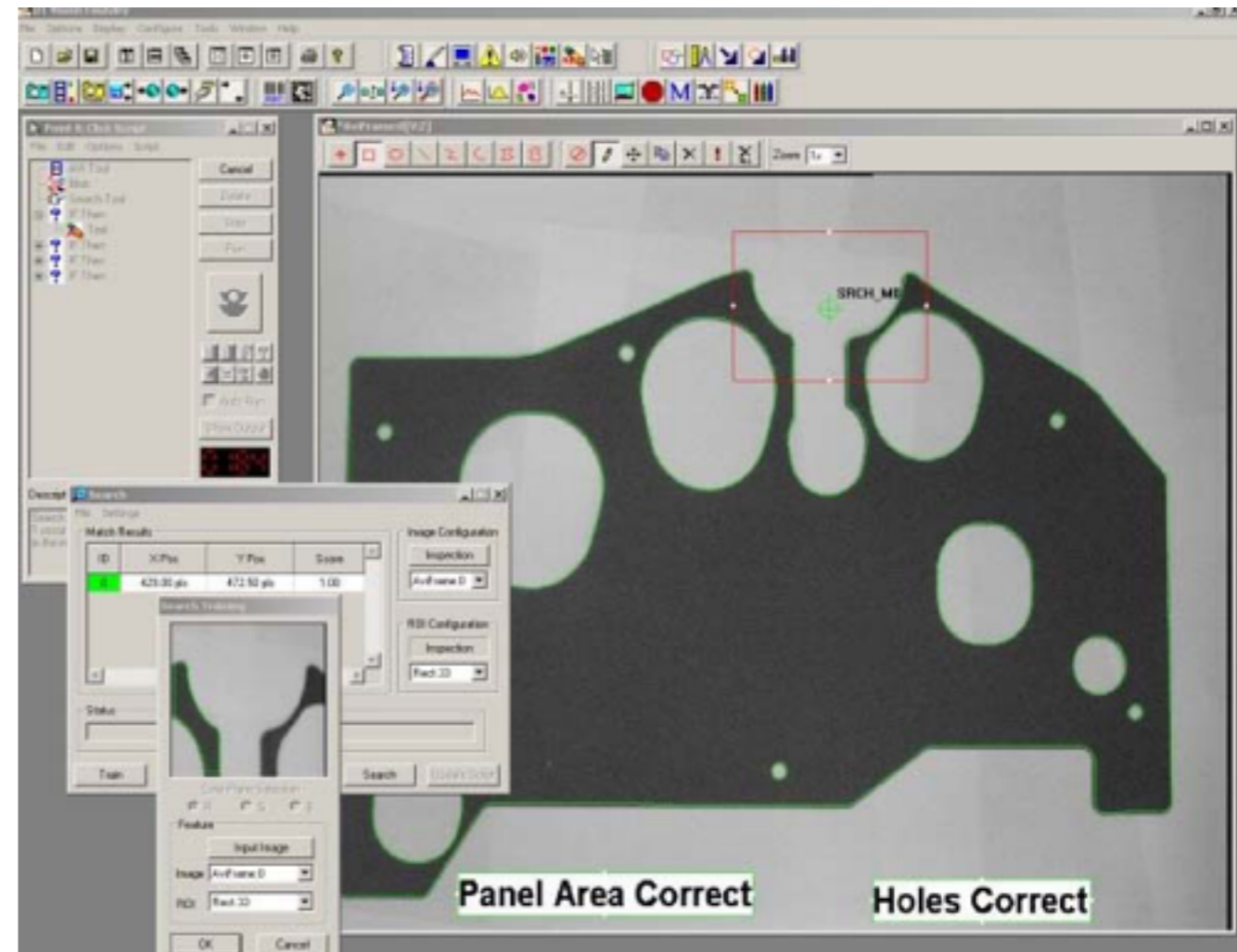

# Optical Metrology History

Vision-Based Metrology inspection systems evolved from the combination of microscopes, cameras and optical comparators.

**“The combination of vision, autofocus laser, rotary indexer, and tactile input allows to even measure features and geometry you can’t see,” Frost says. Measurement can be expressed as 3D reports in the forms of charts and models as opposed to long tables of X-Y data. This makes reporting and decision making much faster and easier.**

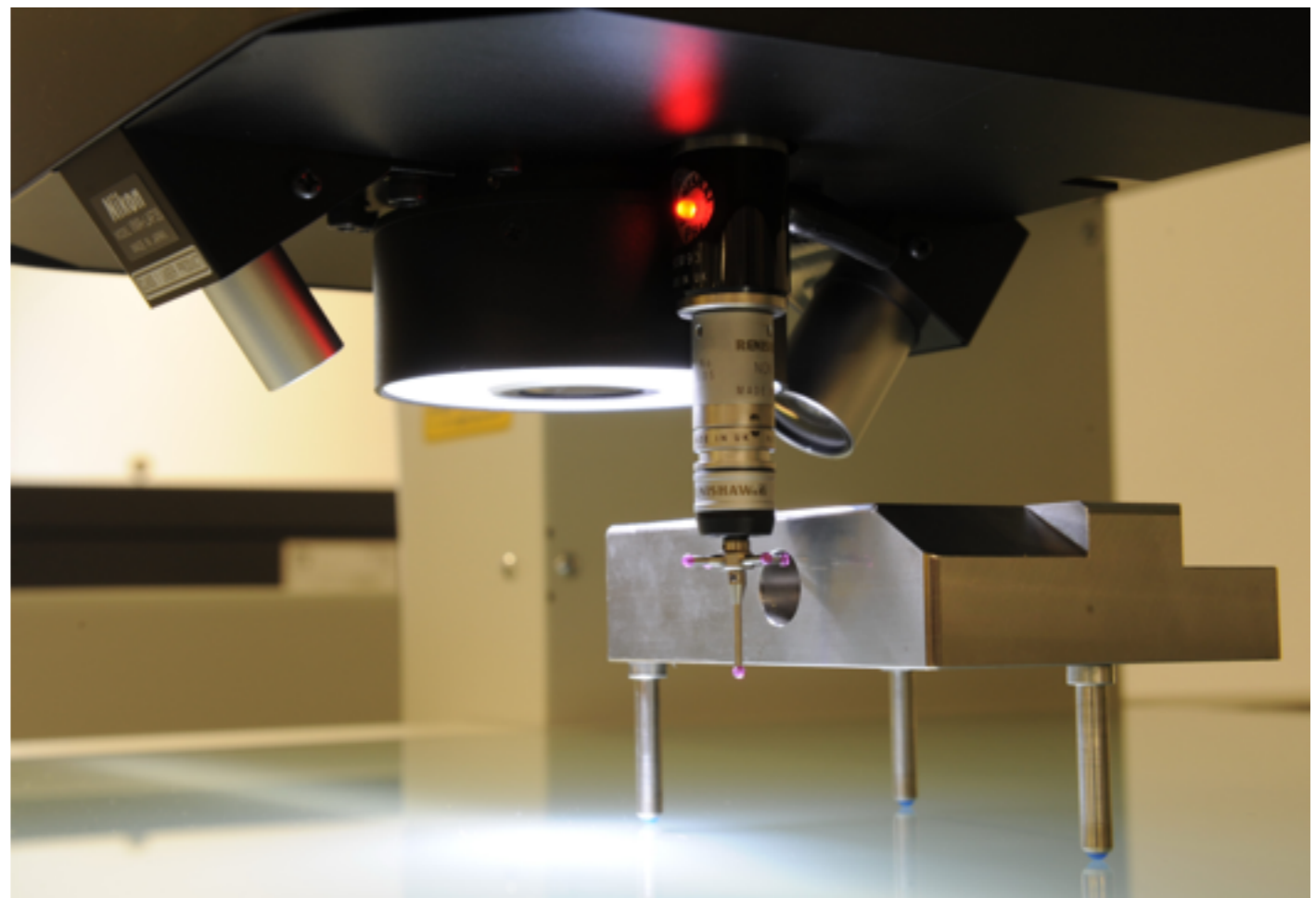

# Optical Metrology History

Vision-Based Metrology is extensively used in general industrial applications such as the manufacturing of:

- Electronics
- Automotive
- Aerospace
- Pharmaceutical
- Consumer products

Vision-Based Metrology is being utilized in the automatic identification and data collection market as a complementary or alternative technology to traditional laser scanning devices for reading bar codes.

# Optical Metrology History

Early systems were integrated into packaging lines for **optical character recognition** to check the accuracy of product codes and label information.

Today, high-resolution cameras, advances in software and imaging processors, and the availability of powerful, inexpensive compact computers have made **vision systems faster and more reliable than ever.**





# Who needs a vision system?

- Vision system may be needed for **high production product inspection** CD and pharma industries
- They provide a means of increasing yield-that is, the **ratio of good parts to bad parts.**
- When a serial defect is spotted, the system not only recognizes it **but can stop the conveyor and inform the operator of the defect** and its magnitude.

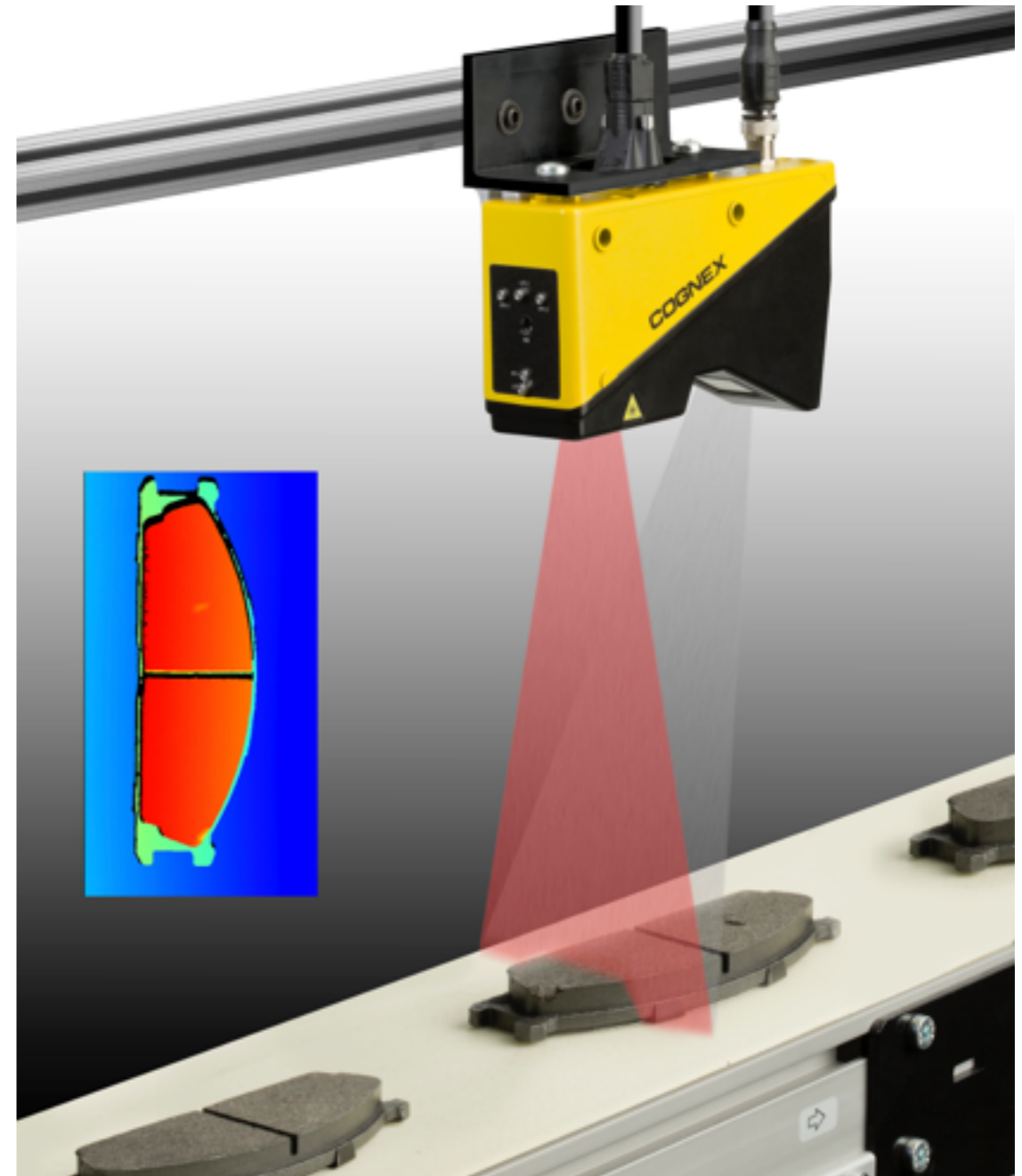

# Vision system - Automobiles

- Vision Based Metrology is now being used to focus on the movement of objects along with their deformation
- This is being used in many car wreck investigations



# Vision system - Automobiles

- Two consecutive images were grabbed from a high speed video sequence
- A displacement field of a car at a certain moment is presented
- The deformation pattern was obtained from the principle vector analysis
- This analysis allows the representation of the deformation pattern.

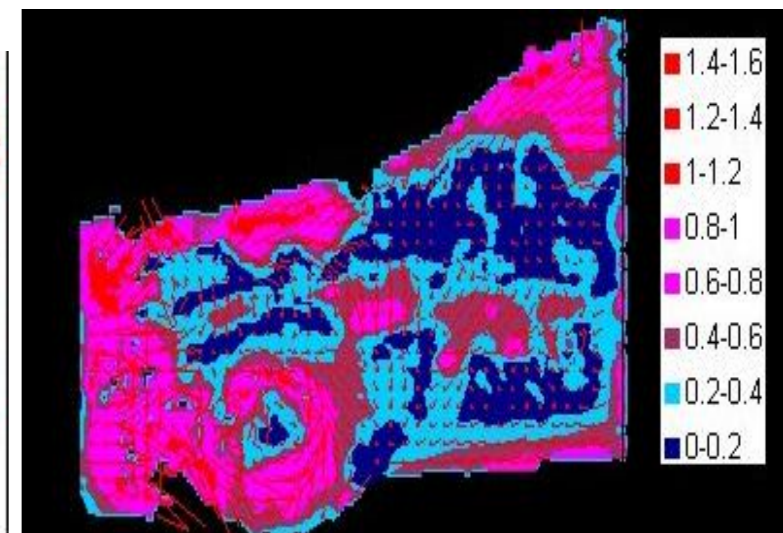
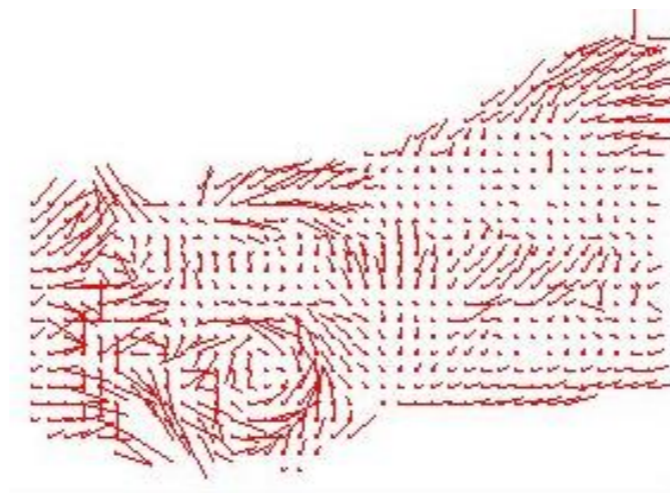
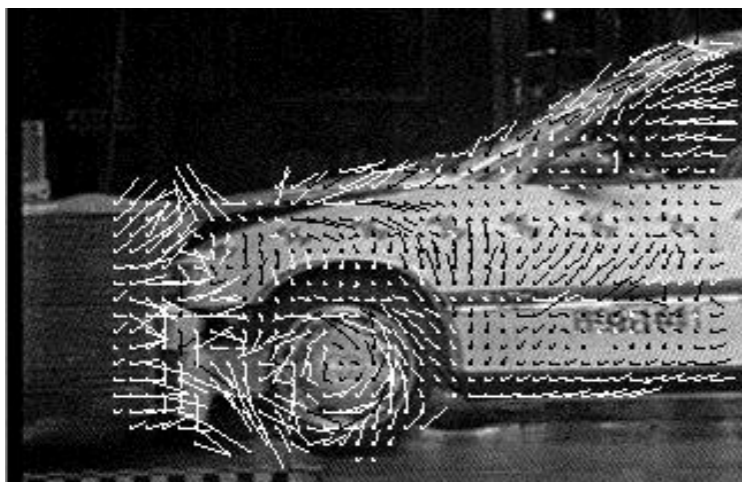



# Vision system - Deformation

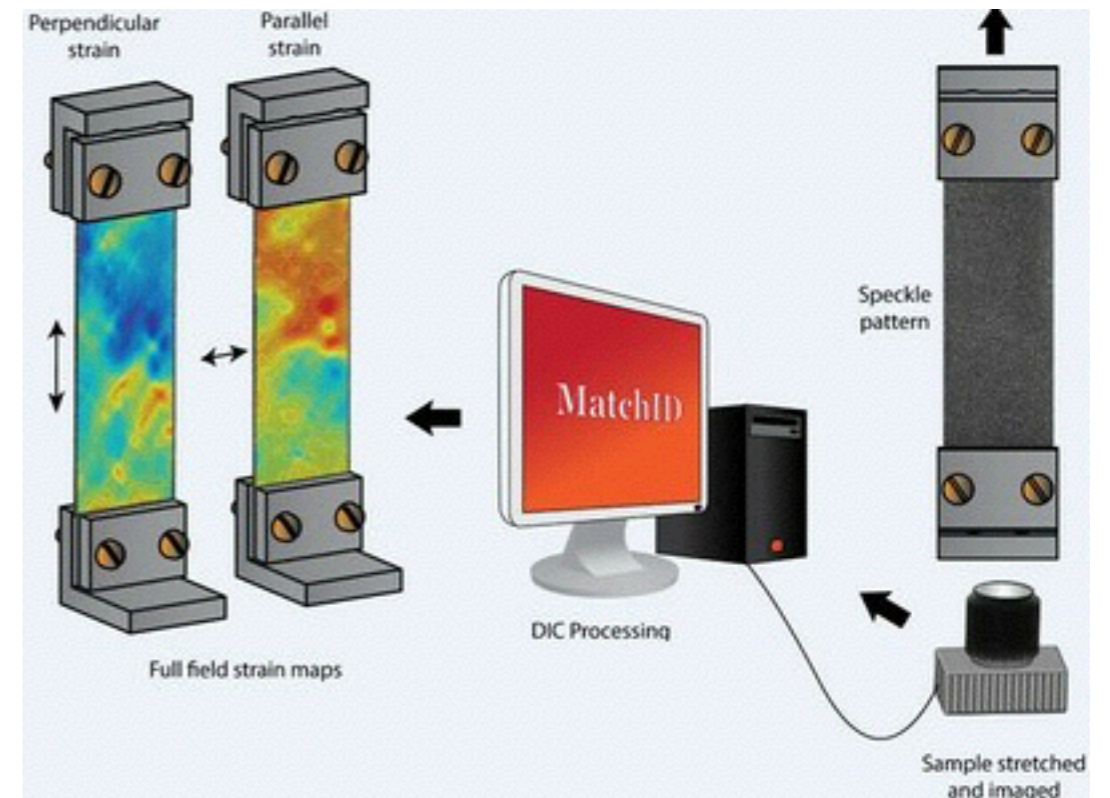
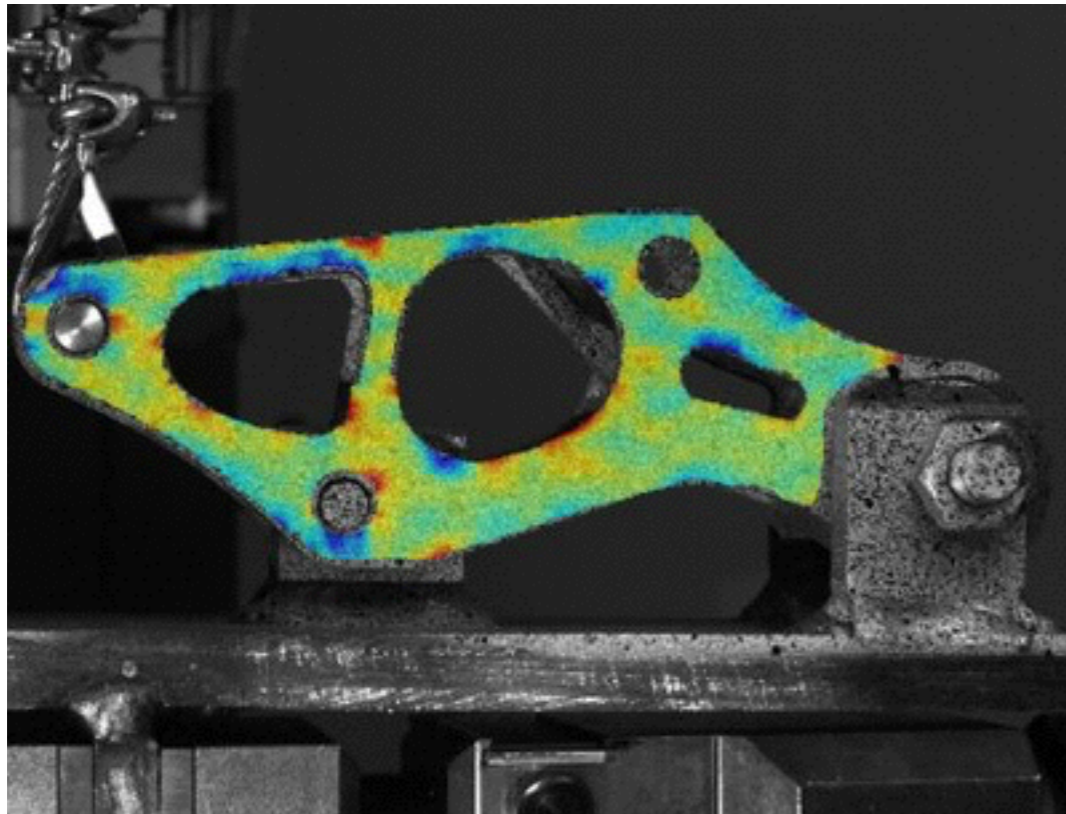

# Basic Optical Principles

# Wave Motion. The Electromagnetic Spectrum

A snapshot of a harmonic wave that propagates in z-direction

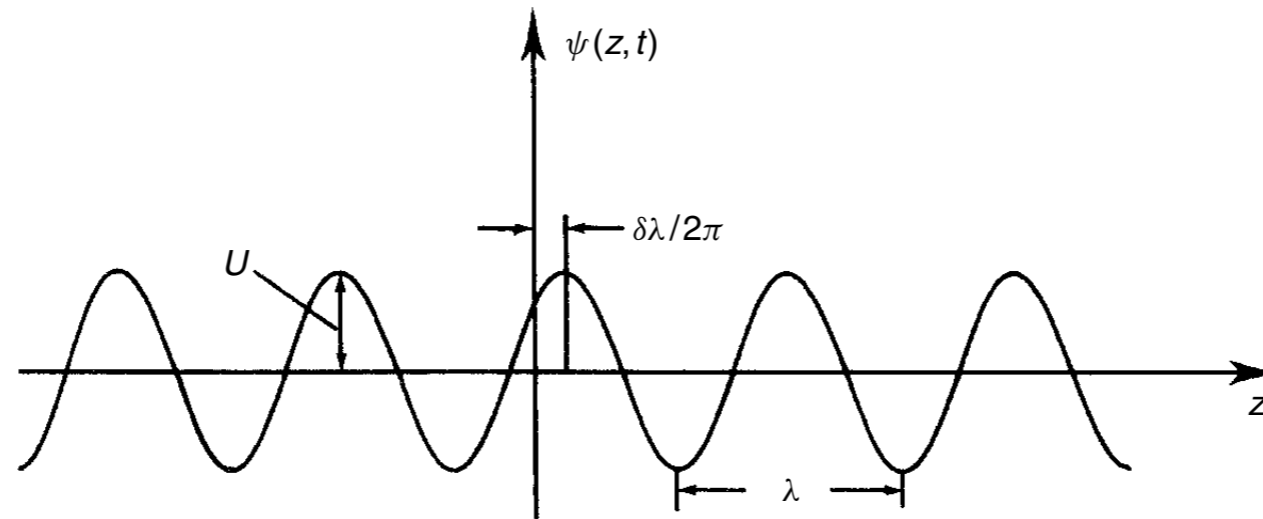

Figure 1.1 Harmonic wave

The disturbance is given by:

$$\psi(z, t) = U \cos \left[ 2\pi \left( \frac{z}{\lambda} - \nu t \right) + \delta \right]$$

$U$  = the amplitude

$\lambda$  = the wavelength

$\nu$  = the frequency (the number of waves per unit time)

$k = 2\pi/\lambda$  the wave number

The relation between frequency and wavelength:

$$\lambda \nu = v$$

$v$  = the wave velocity

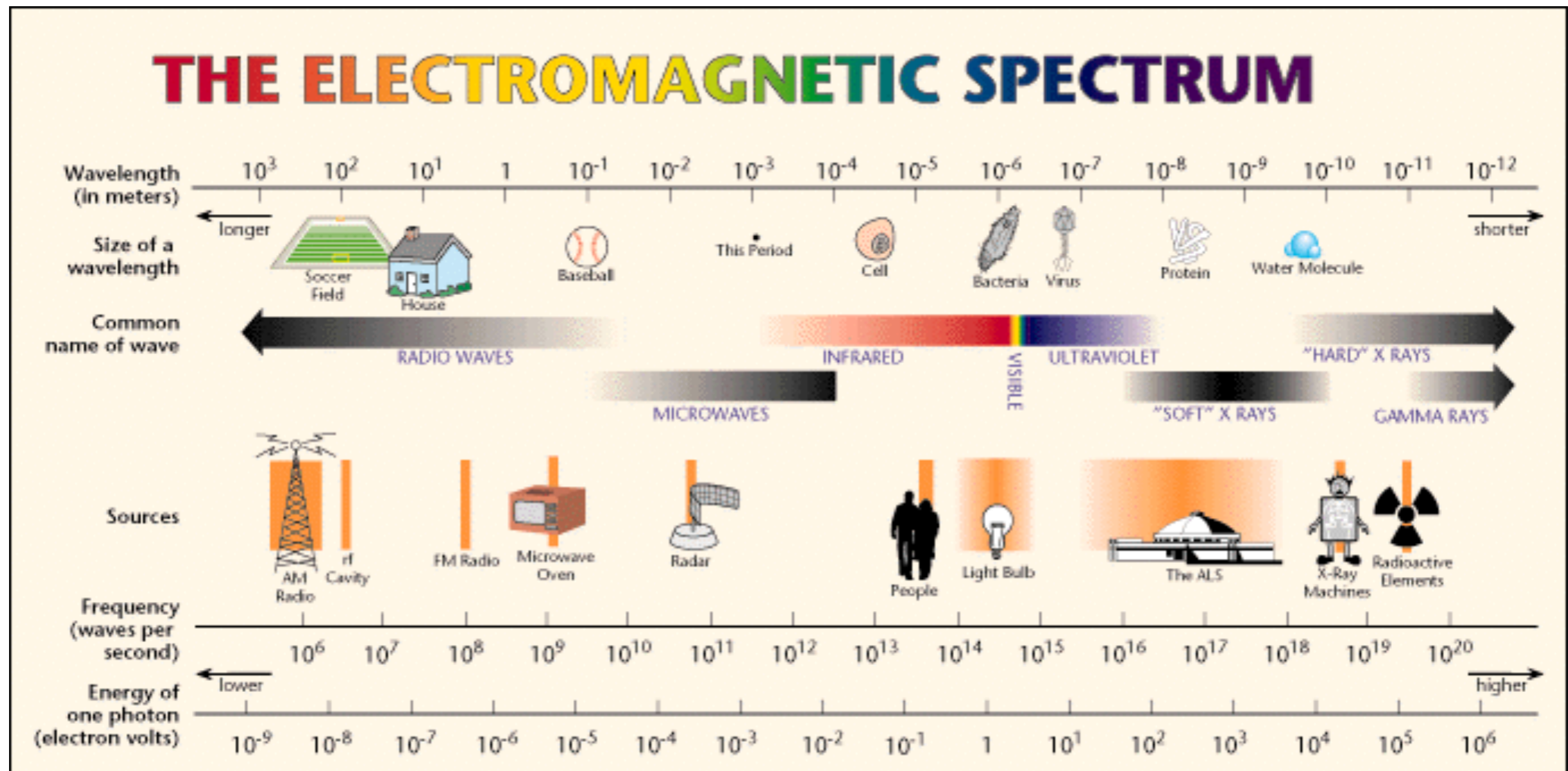

$\psi(z, t)$  might represent the field in an electromagnetic wave for which we have

$$v = c = 3 \times 10^8 \text{ m/s}$$

The ratio of the speed  $c$  of an electromagnetic wave in vacuum to the speed  $v$  in a medium is known as the absolute index of refraction  $n$  of that medium

$$n = \frac{c}{v} \tag{1.3}$$



Although it does not really affect our argument, we shall mainly be concerned with visible light where

$$\lambda = 400\text{--}700 \text{ nm} \quad (1 \text{ nm} = 10^{-9} \text{ m})$$

$$\nu = (4.3\text{--}7.5) \times 10^{14} \text{ Hz}$$

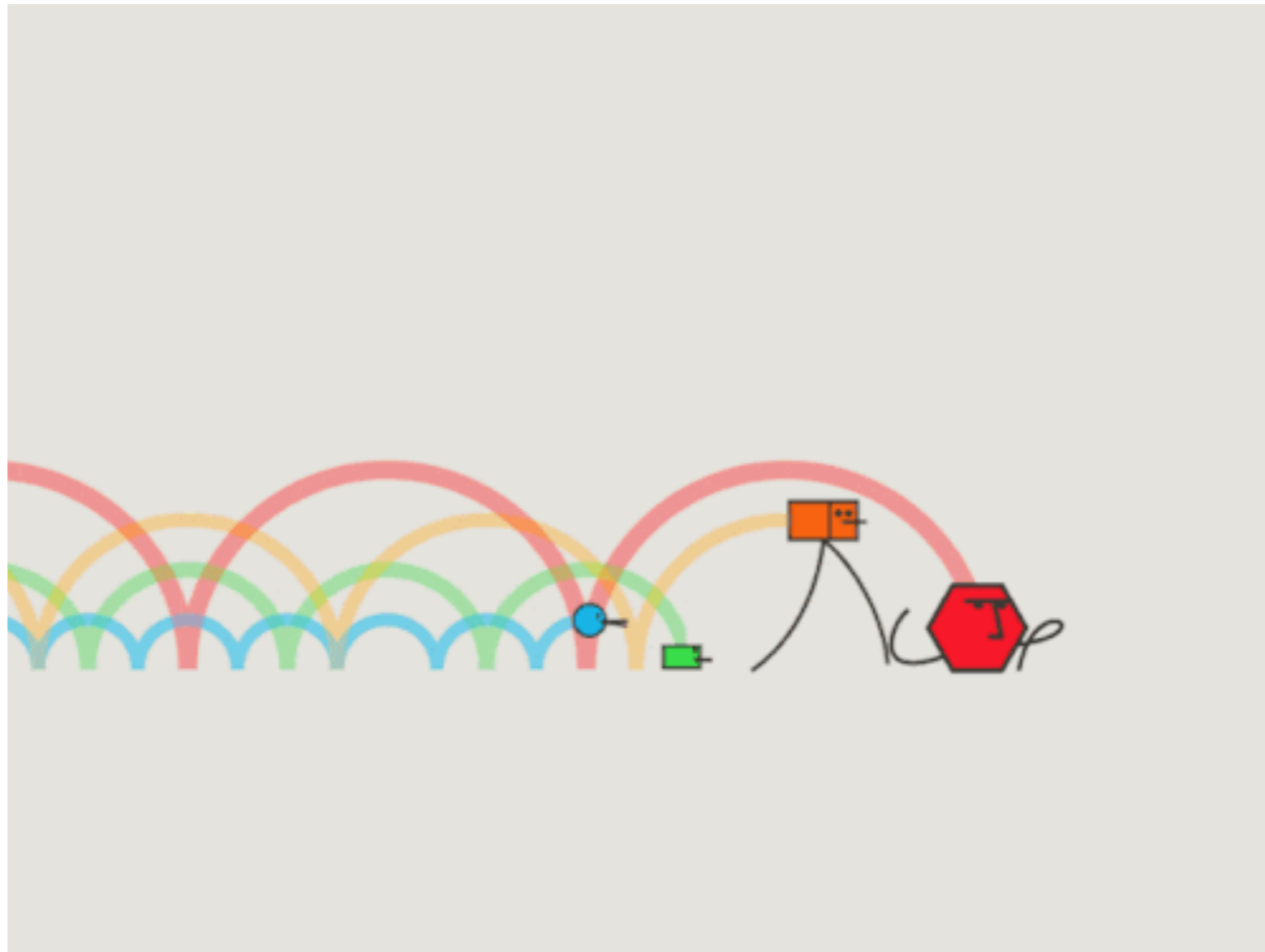

# The Plane Wave. Light Rays

- EM waves are not 2D, but 3D.
- A plane wave that propagates in the direction of  $\mathbf{k}$ -vector.

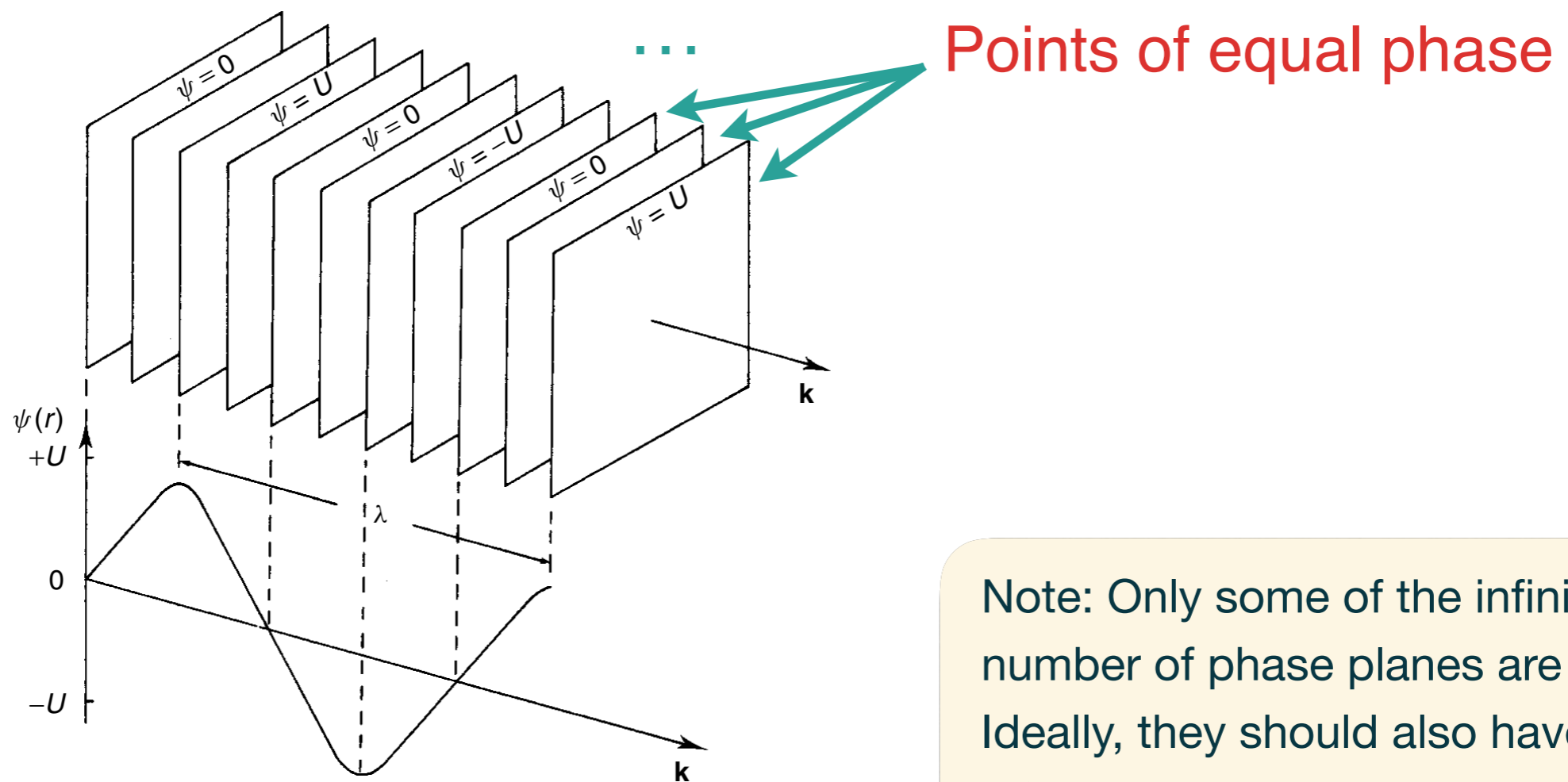

Figure 1.2 The plane wave

Note: Only some of the infinite number of phase planes are drawn. Ideally, they should also have infinite extent.

# The Plane Wave. Light Rays

In the general case where a plane wave propagates in the direction of a unit vector  $\mathbf{n}$ , the expression describing the field at an arbitrary point with radius vector  $\mathbf{r} = (x, y, z)$  is given by:

$$\psi(x, y, z, t) = U \cos[\mathbf{k}\mathbf{n} \cdot \mathbf{r} - 2\pi\nu t + \delta]$$

The scalar product fulfilling the condition  $\mathbf{n} \cdot \mathbf{r} = \text{constant}$  describes a plane which is perpendicular to  $\mathbf{n}$

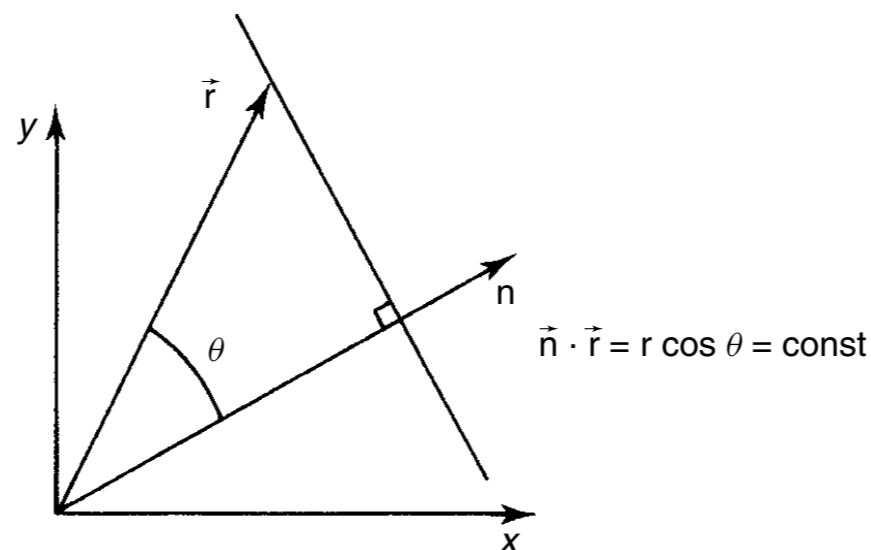

# The Plane Wave. Light Rays

**Light Rays.** They are directed lines that are everywhere perpendicular to the phase planes

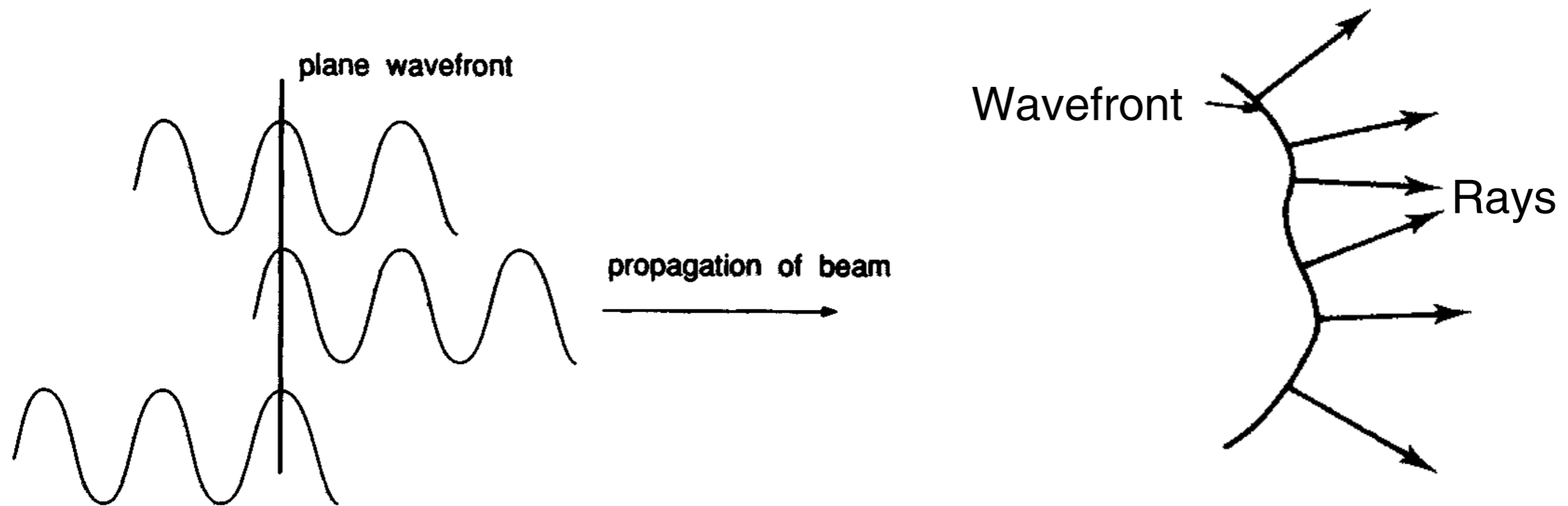



# Phase Difference

$$\psi(z, t) = U \cos \left[ 2\pi \left( \frac{z}{\lambda} - \nu t \right) + \delta \right]$$

Let us for a moment turn back to the plane wave described by Equation (1.1). At two points  $z_1$  and  $z_2$  along the propagation direction, the phases are  $\phi_1 = kz_1 - 2\pi\nu t + \delta$  and  $\phi_2 = kz_2 - 2\pi\nu t + \delta$  respectively, and the phase difference

$$\Delta\phi = \phi_1 - \phi_2 = k(z_1 - z_2) \quad (1.5)$$

The **phase difference** between two points along the propagation direction of a plane wave is equal to the **geometrical path-length difference multiplied by the wave number**.

optical path length =  $n \times$  (geometrical path length)

phase difference =  $k \times$  (optical path length)

# Complex Notation. Complex Amplitude

$$\psi(z, t) = U \cos \left[ 2\pi \left( \frac{z}{\lambda} - vt \right) + \delta \right]$$

Can be written as

$$\psi(x, y, z, t) = \text{Re}\{U e^{i(\phi - 2\pi vt)}\}$$

where

$$\phi = k\mathbf{n} \cdot \mathbf{r} + \delta$$

spatial dependent phase

Spatial and temporal parts factorize

$$\psi(x, y, z, t) = U e^{i(\phi - 2\pi vt)} = U e^{i\phi} e^{-i2\pi vt}$$

In Optical Metrology interest lies in spatial distribution

$$u = U e^{i\phi}$$

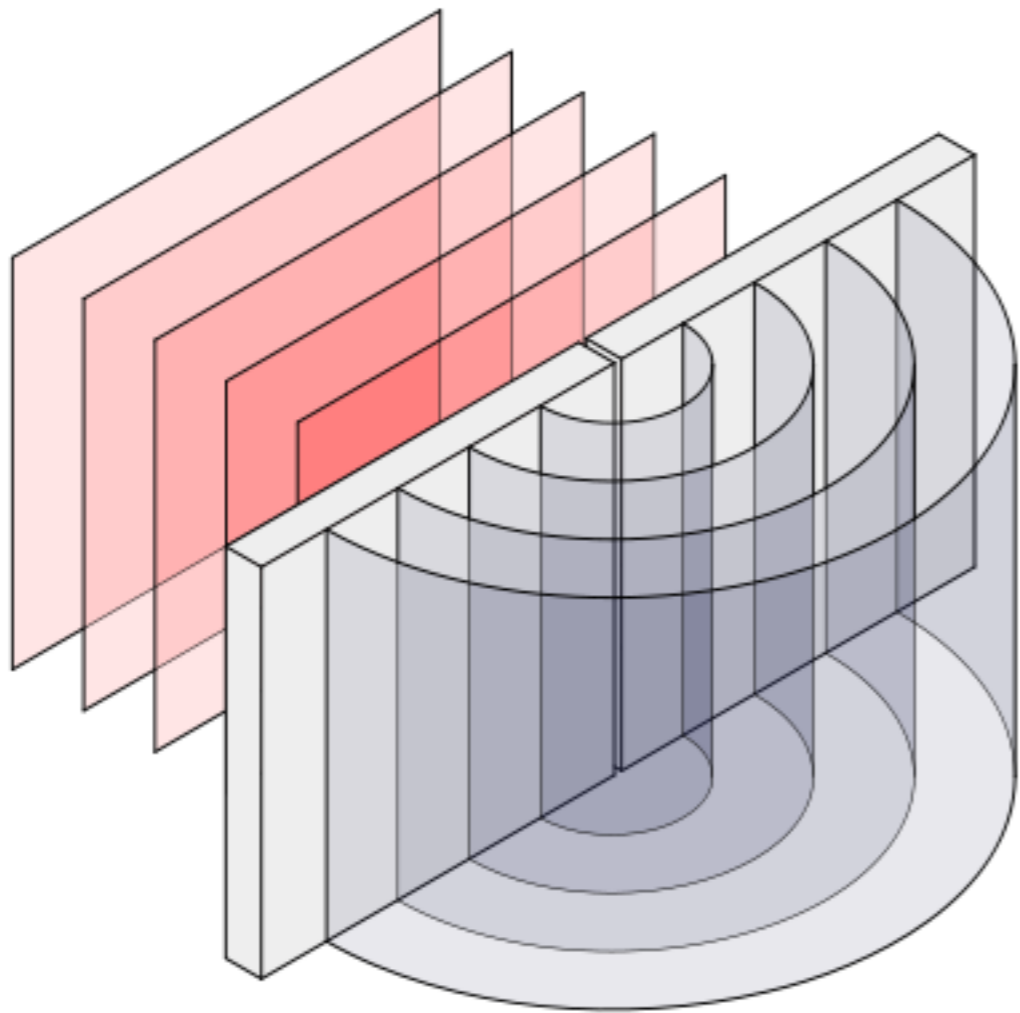

**Cylindrical wavefront**

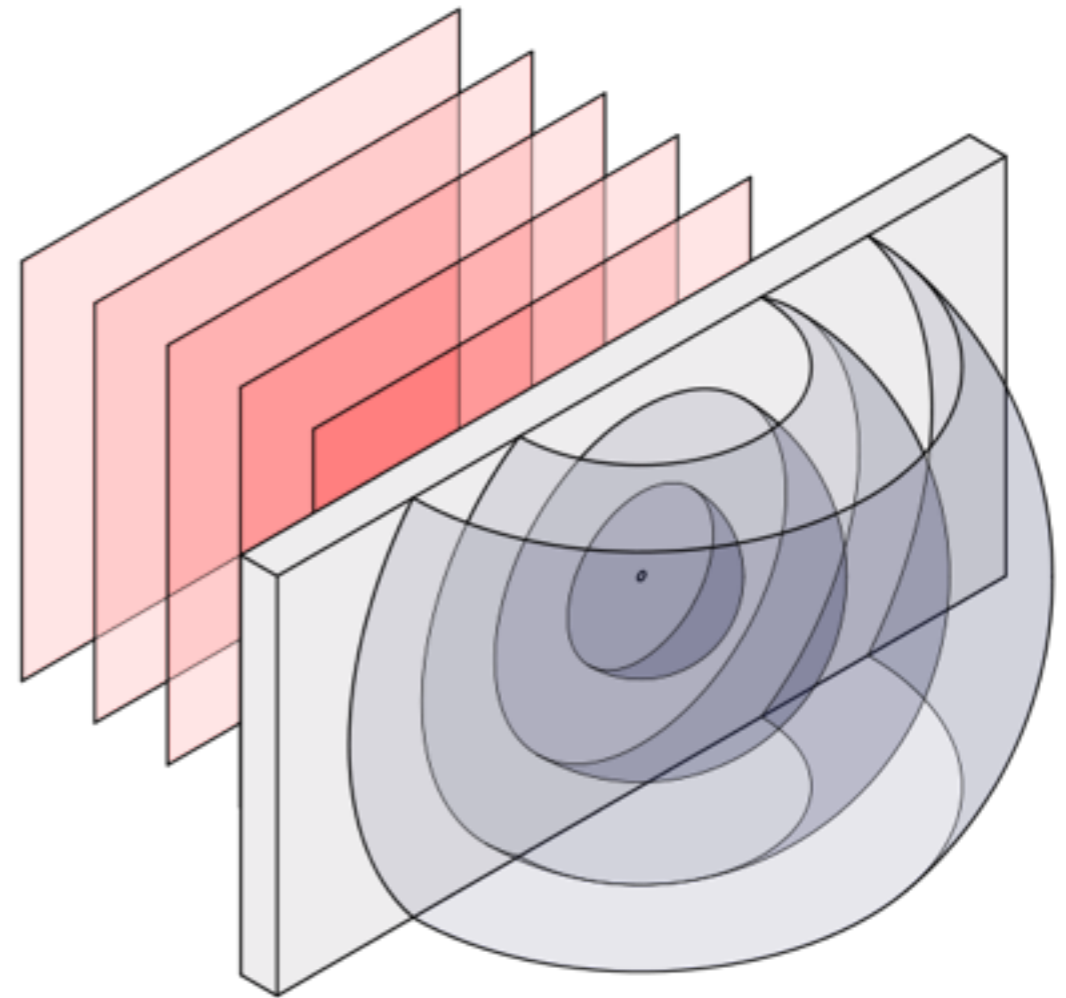

**Spherical wavefront**

A more complicated wavefront resulting from reflection from a rough surface

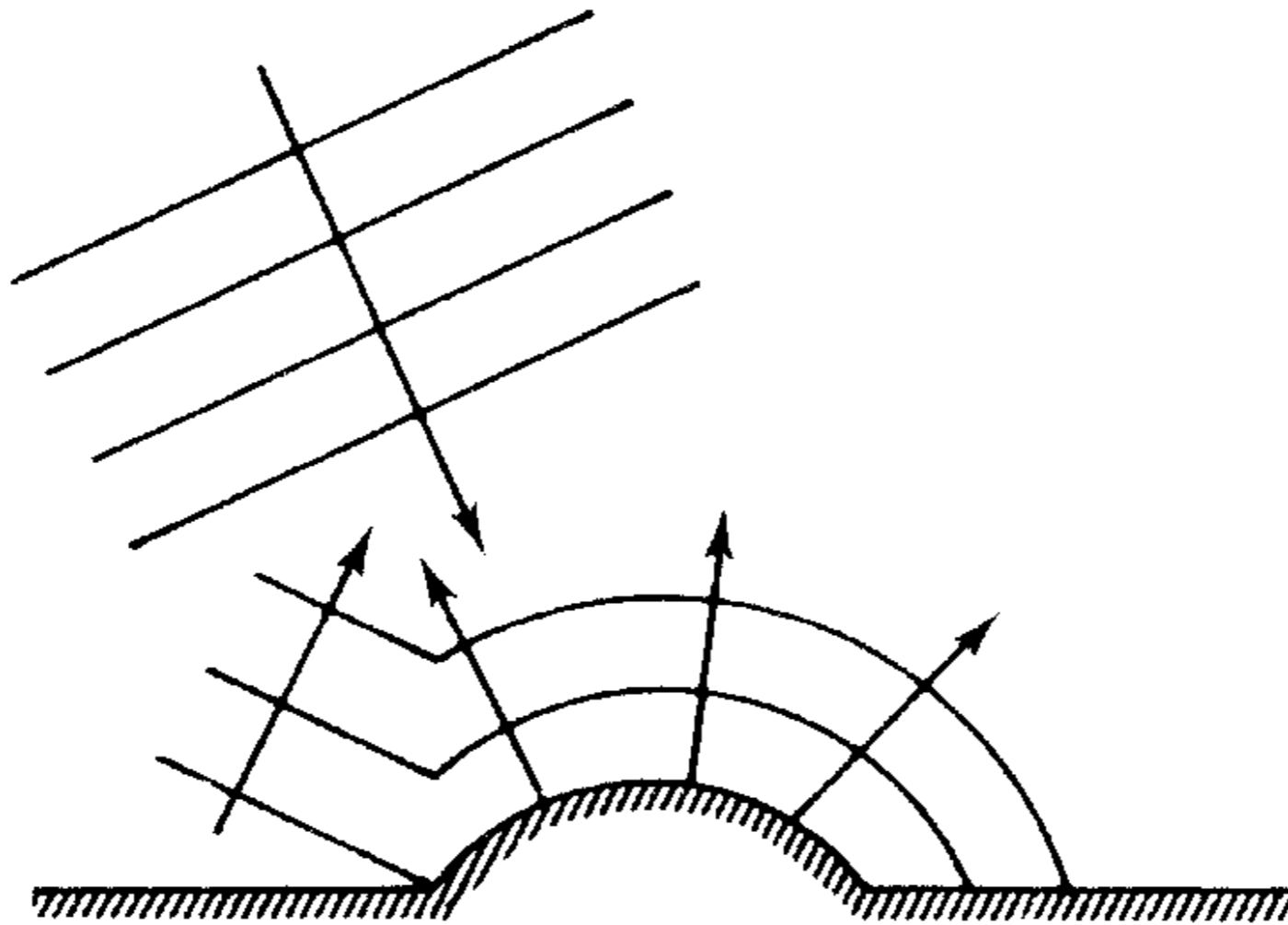



# The Spherical Wave

A spherical wave, is a wave emitted by a point source, given by:

$$u = \frac{U}{r} e^{ikr}$$

$r$  is the radial distance to the point source.

The amplitude decreases as the inverse of the distance from the point source.

Consider a point source in  $(x_0, y_0)$ ,

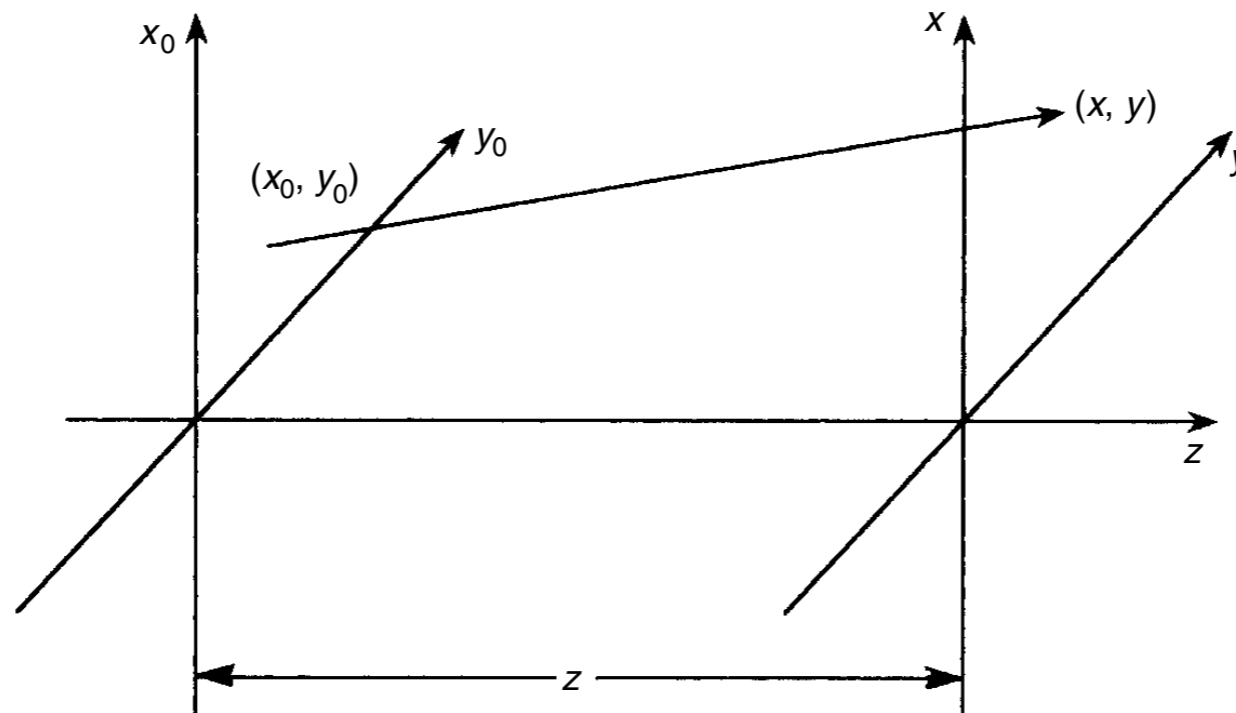

$$u = \frac{U}{r} e^{ikr}$$

The field amplitude in a plane parallel to the  $x_0y_0$ -plane at a distance  $z$ , approximating  $r$  by a binomial expansion,

$$r = \sqrt{z^2 + (x - x_0)^2 + (y - y_0)^2}$$

$$r = z \sqrt{1 + \left(\frac{x - x_0}{z}\right)^2 + \left(\frac{y - y_0}{z}\right)^2} \approx z \left[ 1 + \frac{1}{2} \left(\frac{x - x_0}{z}\right)^2 + \frac{1}{2} \left(\frac{y - y_0}{z}\right)^2 \right]$$

$$u(x, y, z) = \frac{U}{z} e^{ikz} e^{i(k/2z)[(x-x_0)^2 + (y-y_0)^2]}$$

**Fresnel approximation.**

# The Intensity

Recording of field amplitude is impossible.

Most devices register irradiance (effect per unit area).

It is proportional to field amplitude square:

$$I = |u|^2 = U^2$$

# Geometrical Optics

## The three laws of geometrical optics:

1. Rectilinear propagation in a uniform, homogeneous medium.
2. Reflection. On reflection from a mirror, the angle of reflection is equal to the angle of incidence (see Figure 1.8). In this context we mention that on reflection (scattering) from a rough surface (roughness  $>\lambda$ ) the light will be scattered in all directions (see Figure 1.9).

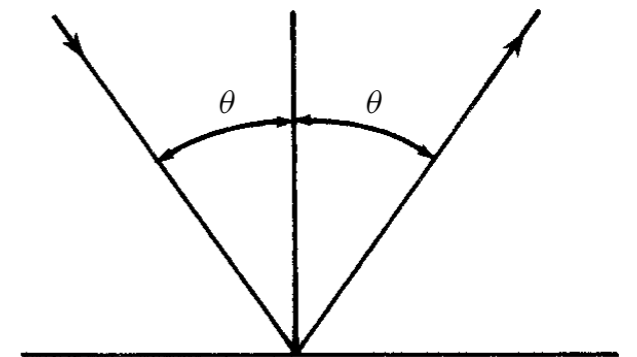

Figure 1.8 The law of reflection

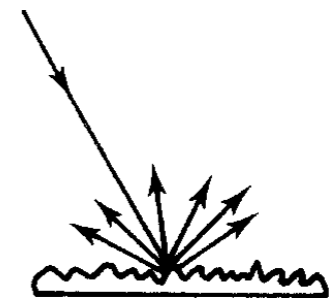

Figure 1.9 Scattering from a rough surface

## The three laws of geometrical optics:

3. Refraction. When light propagates from a medium of refractive index  $n_1$  into a medium of refractive index  $n_2$ , the propagation direction changes according to

$$n_1 \sin \theta_1 = n_2 \sin \theta_2 \quad (1.16)$$

where  $\theta_1$  is the angle of incidence and  $\theta_2$  is the angle of emergence (see Figure 1.10).

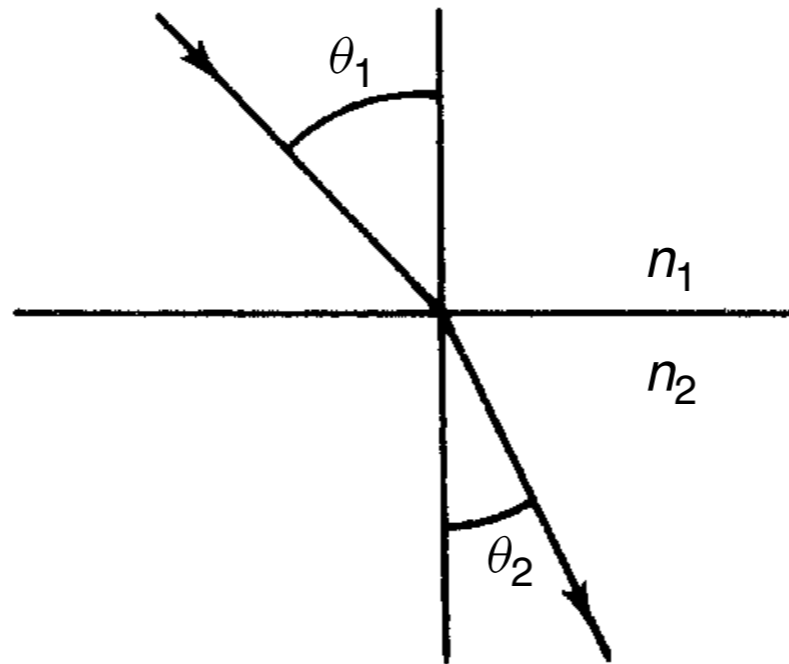

**Figure 1.10** The law of refraction

# Light - Refraction

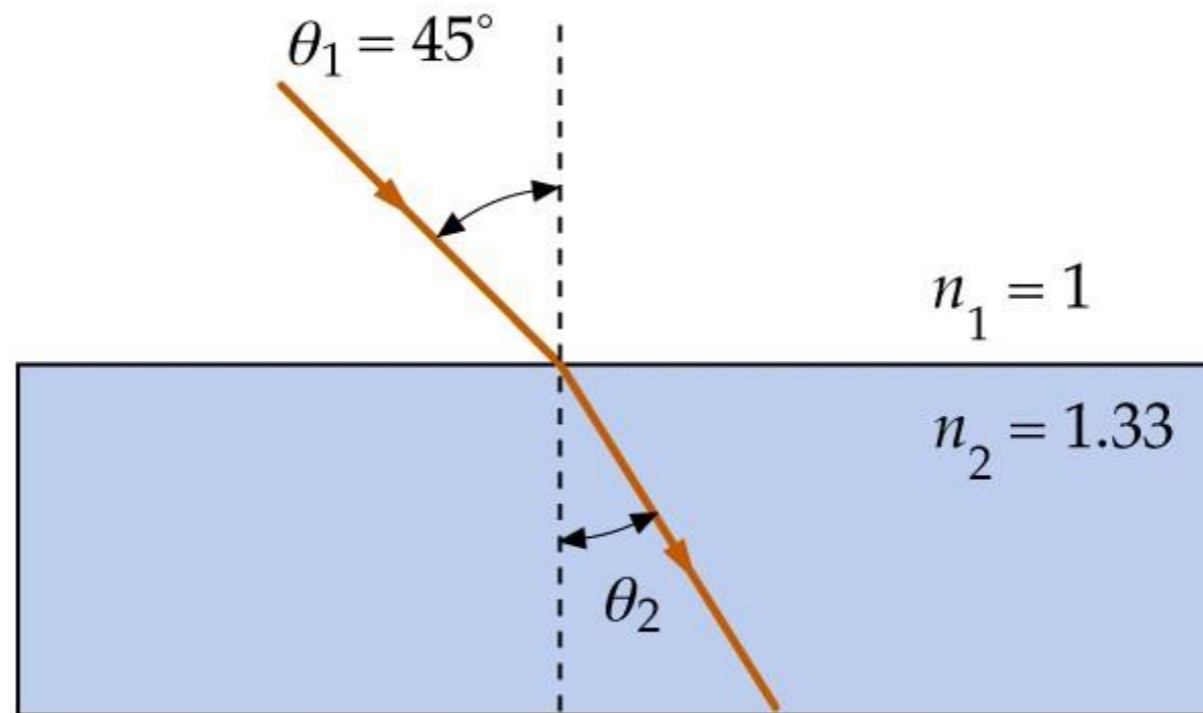

Snell's Law

$$n_1 \sin \theta_1 = n_2 \sin \theta_2$$

$$\theta_2 = \sin^{-1}[(n_1/n_2) \sin \theta_1]$$
$$\theta_2 = 32.12^\circ$$



# Light - Refraction

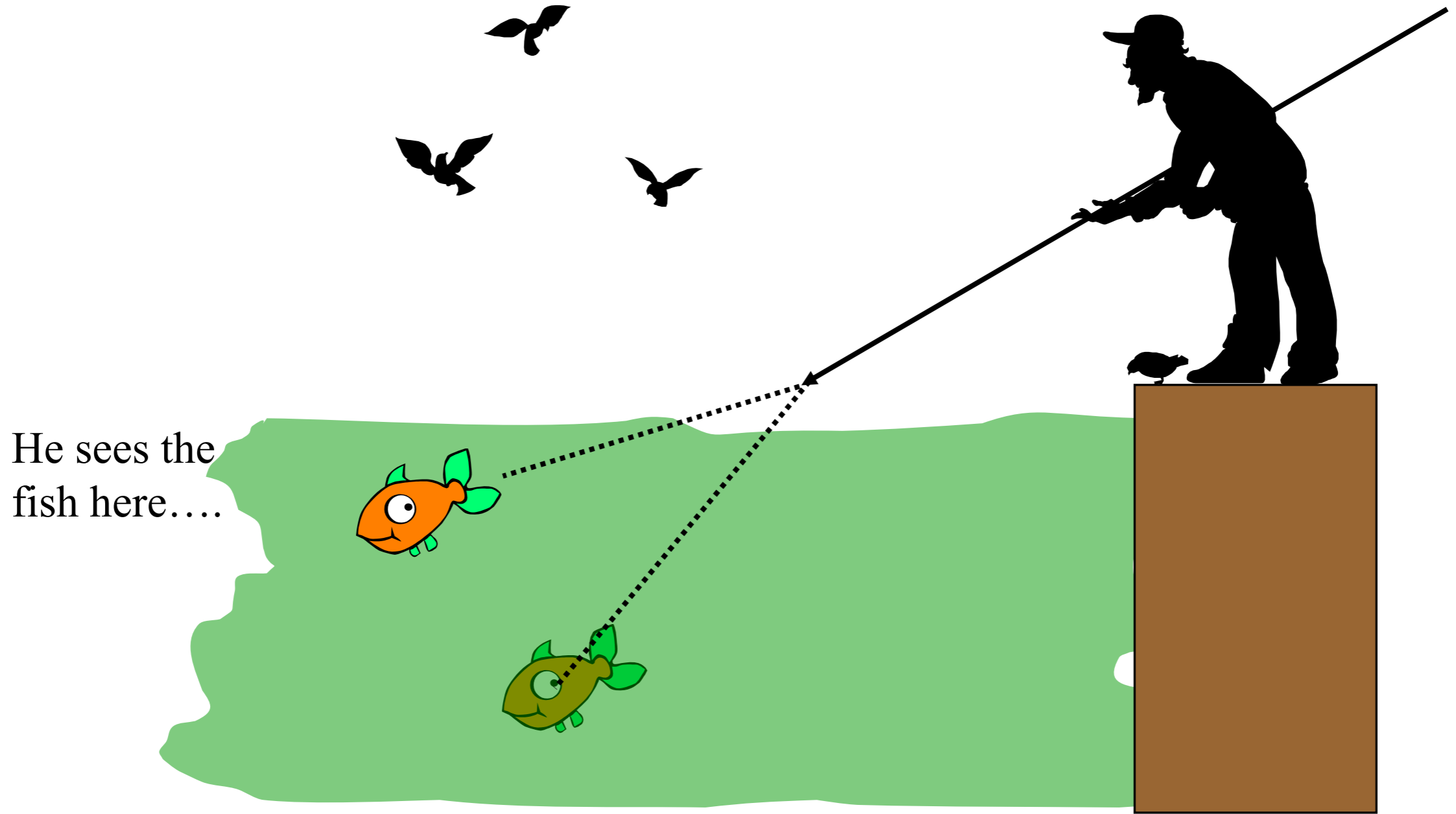

He sees the  
fish here....

But it is really here!!

# Light - Refraction

From Equation (1.16) we see that when  $n_1 > n_2$ , we can have  $\theta_2 = \pi/2$ . This occurs for an angle of incidence called the critical angle given by

$$\sin \theta_1 = \frac{n_2}{n_1} \quad (1.17)$$

This is called total internal reflection

Is this useful?

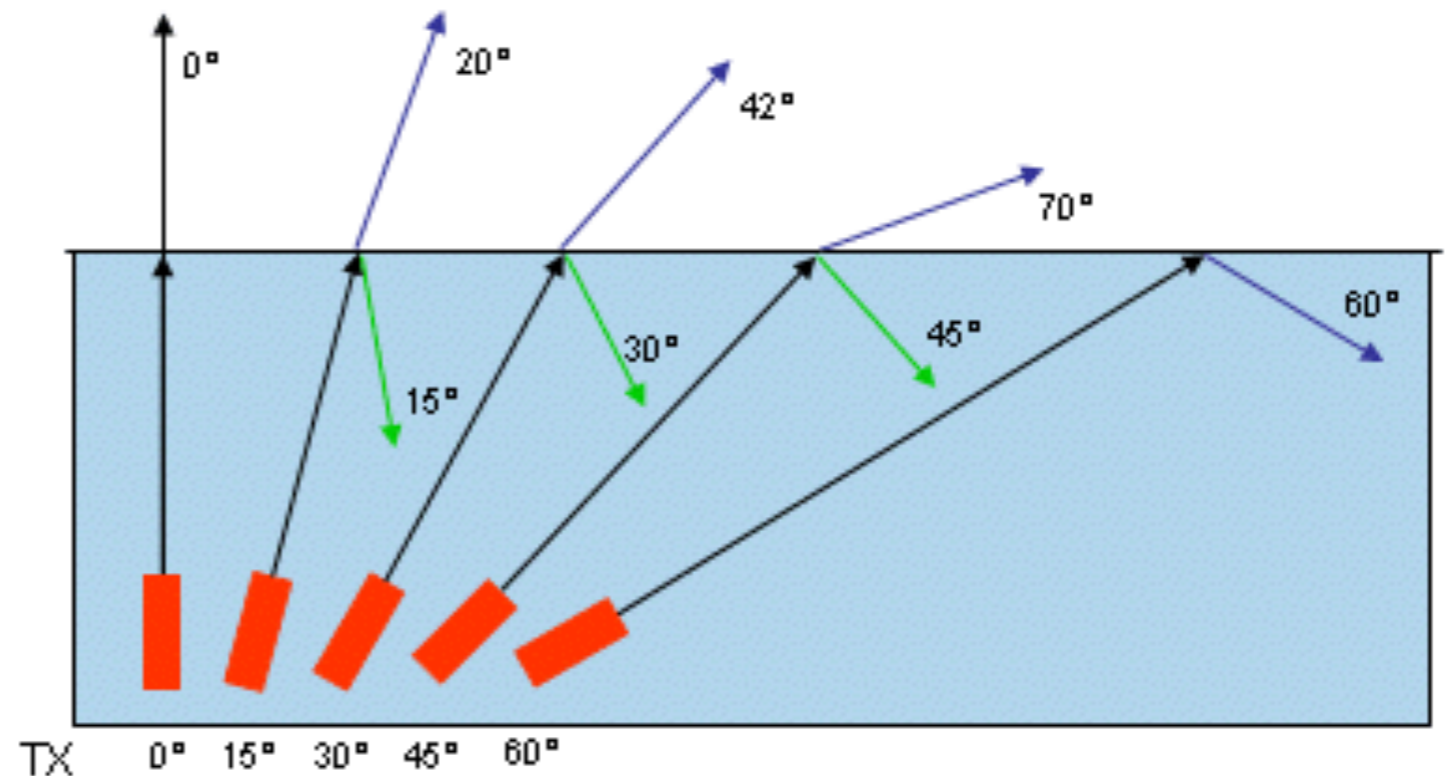

# Light – Total Internal Dispersion

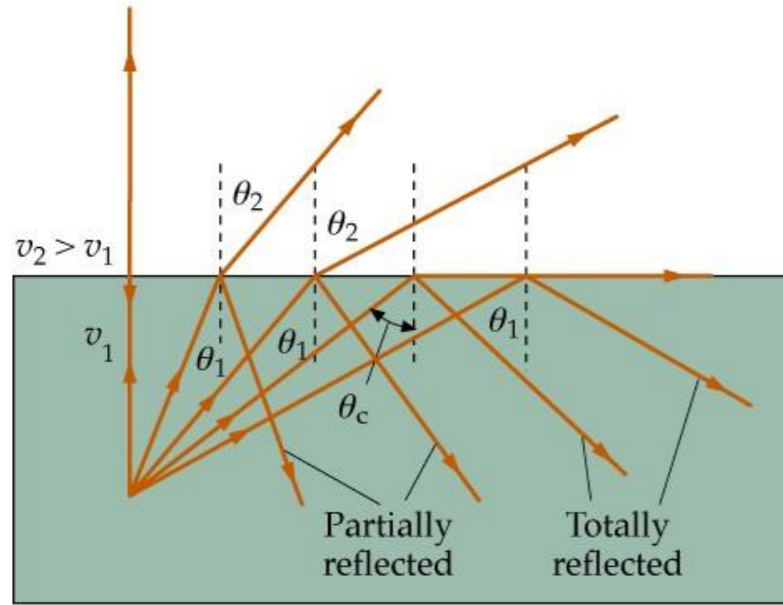

(a)

$$\sin \theta_c = \frac{n_2}{n_1} \sin 90^\circ = \frac{n_2}{n_1}$$

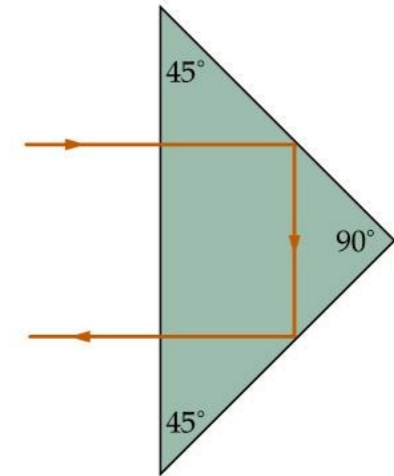

(b)

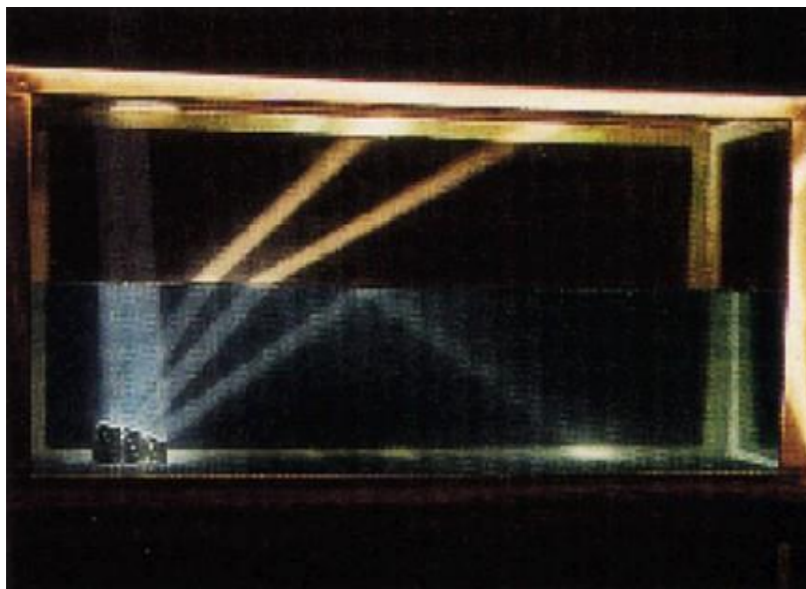

## Fiber Optics

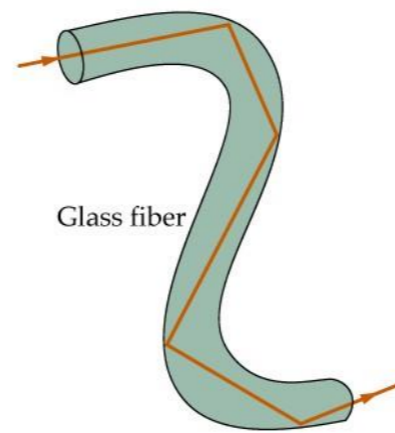

(a)

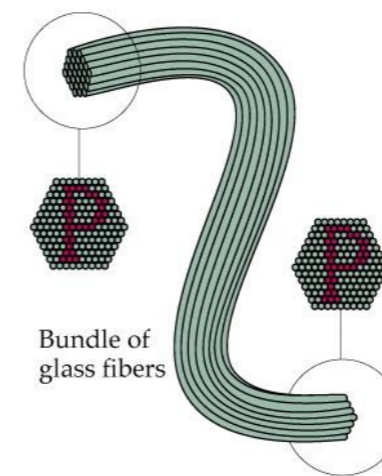

(b)

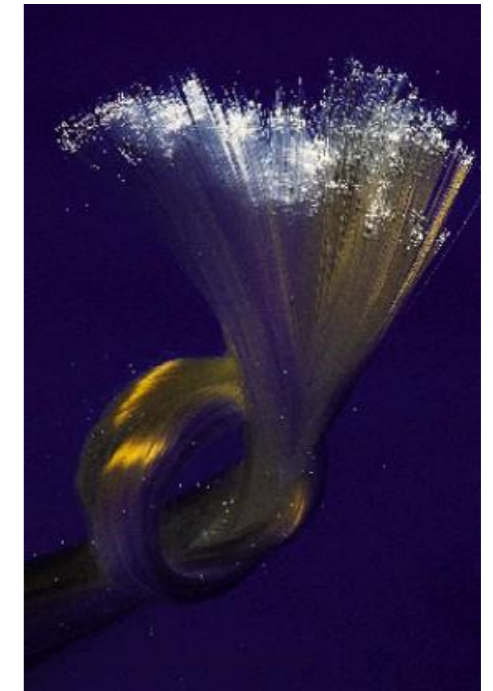

# The Simple Convex (Positive) Lens

Figure 1.11 illustrates the imaging property of the lens. From an object point  $P_o$ , light rays are emitted in all directions. That this point is imaged means that all rays from  $P_o$  which pass the lens aperture  $D$  intersect at an image point  $P_i$ .

To find  $P_i$ , it is sufficient to trace just two of these rays. Figure 1.12 shows three of them. The distance  $b$  from the lens to the image plane is given by the lens formula

$$\frac{1}{a} + \frac{1}{b} = \frac{1}{f} \quad (1.18)$$

and the transversal magnification

$$m = \frac{h_i}{h_o} = \frac{b}{a} \quad (1.19)$$

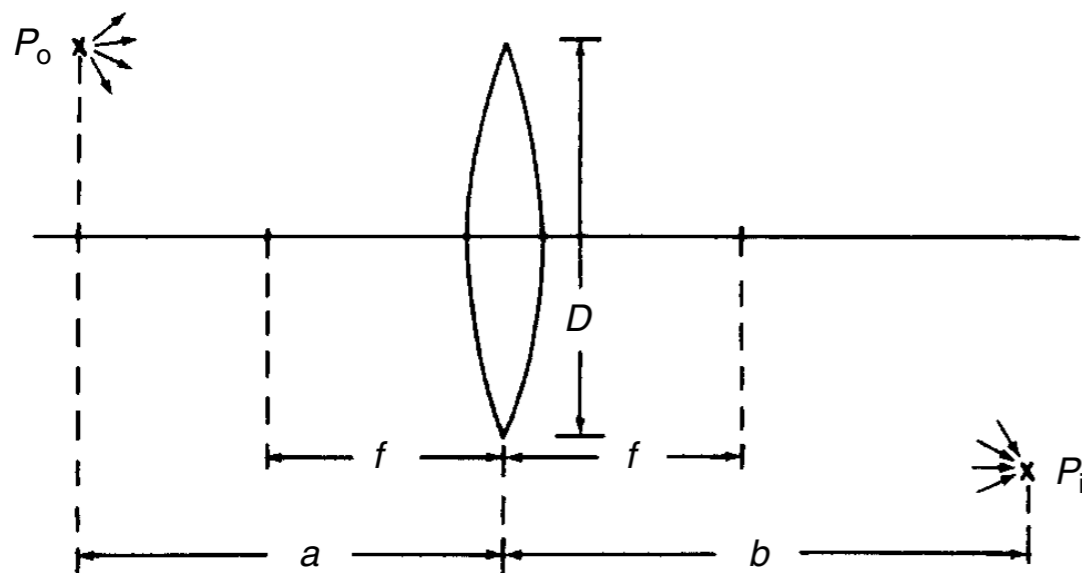

Figure 1.11

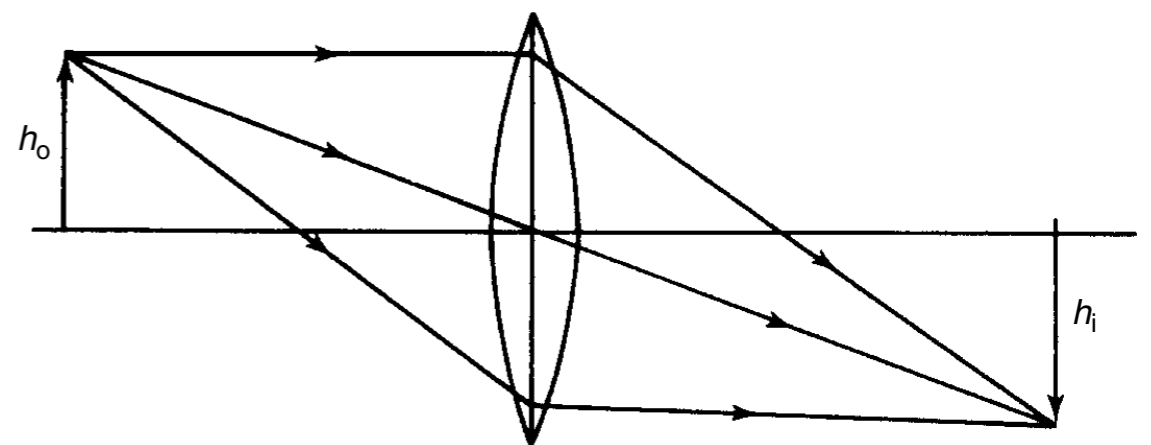

Figure 1.12

# The Simple Convex (Positive) Lens

- (a) A point source lying on the optical axis forming a **spherical diverging wave** that is converted to a converging wave and focuses onto a point on the optical axis
- (b) The **point source** is lying on-axis at a distance from the lens equal to the focal length  $f$ . We then get a **plane wave** that propagates along the optical axis.
- (c) The **point source is displaced** along the focal plane a distance  $h$  from the optical axis. We then get a **plane wave propagating in a direction that makes an angle  $\theta$**  to the optical axis where

$$\tan \theta = h/f$$

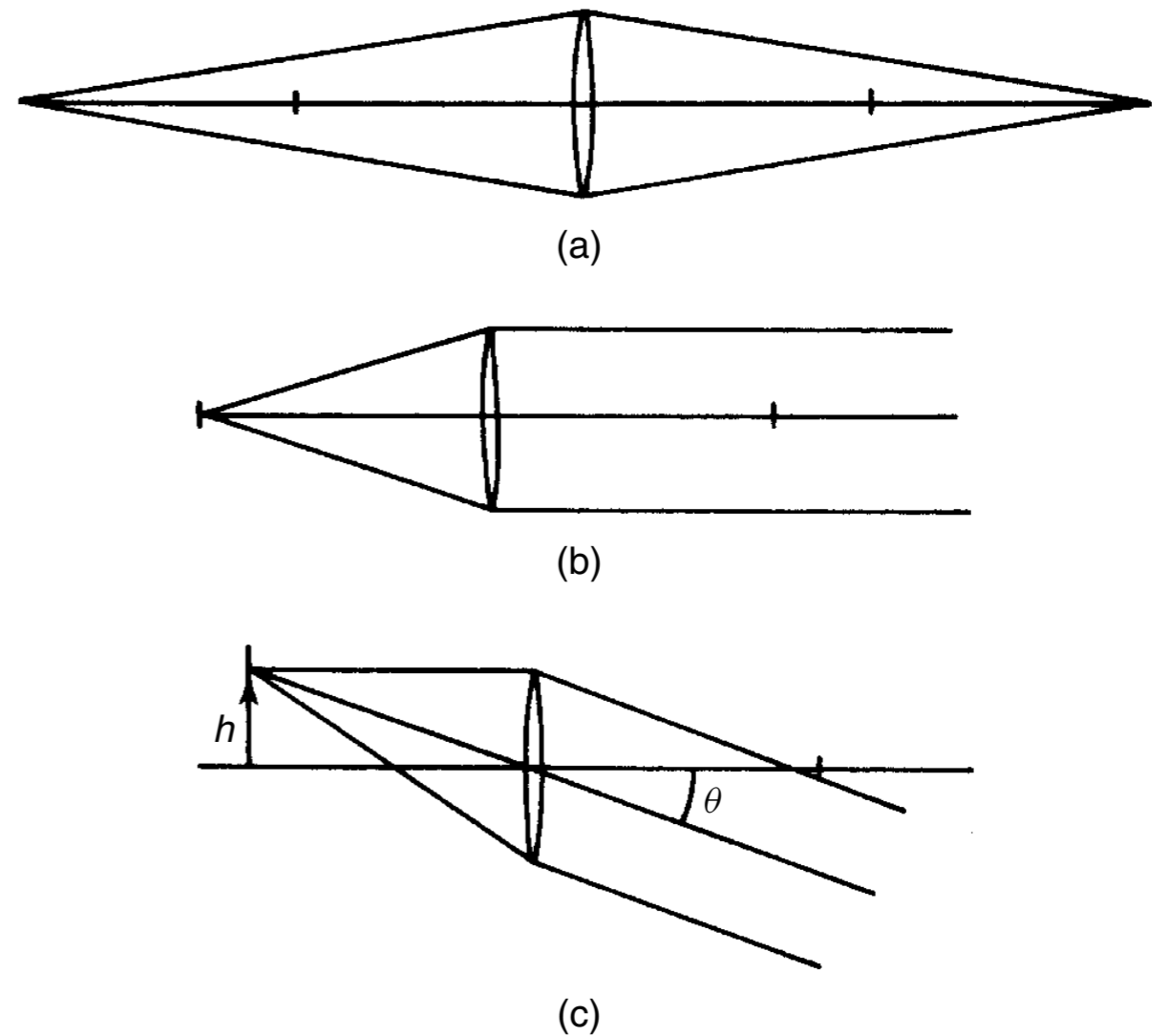
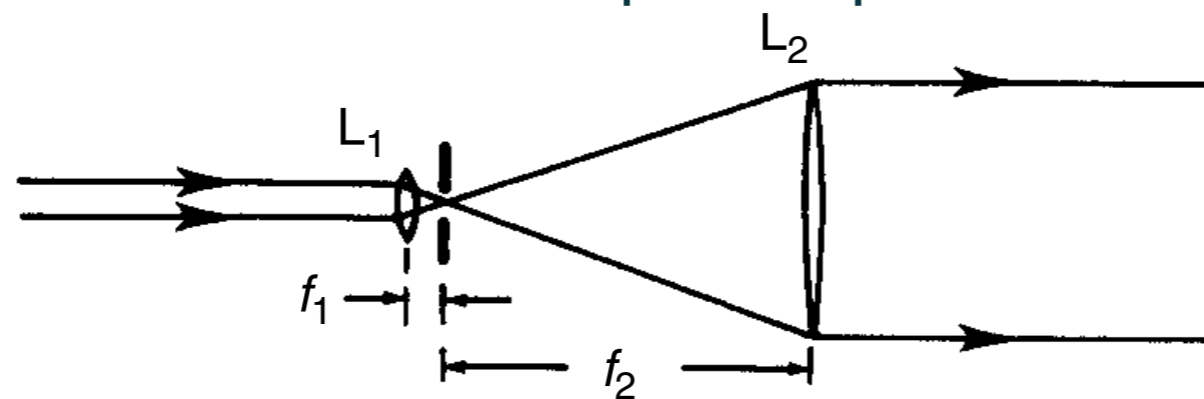

Figure 1.13

# A Plane-Wave Set-Up

- The set-up to form a uniform, **expanded plane wave from a laser beam**.
- The laser beam is a plane wave with a small cross-section, typically 1 mm. To increase the cross-section, the beam is first directed through lens  $L_1$ , usually a microscope objective which is a lens of very short focal length  $f_1$ .
- A lens  $L_2$  of greater diameter and longer focal length  $f_2$  is placed as shown in the figure.
- In the focal point of  $L_1$  a small opening (a pinhole) of diameter typically  $10\ \mu\text{m}$  is placed. In that way, **light which does not fall at the focal point is blocked**.
- Such stray light is due to dust and impurities crossed by the laser beam on its way via other optical elements (like mirrors, beamsplitters, etc.) and it causes the beam not to be a perfect plane wave.

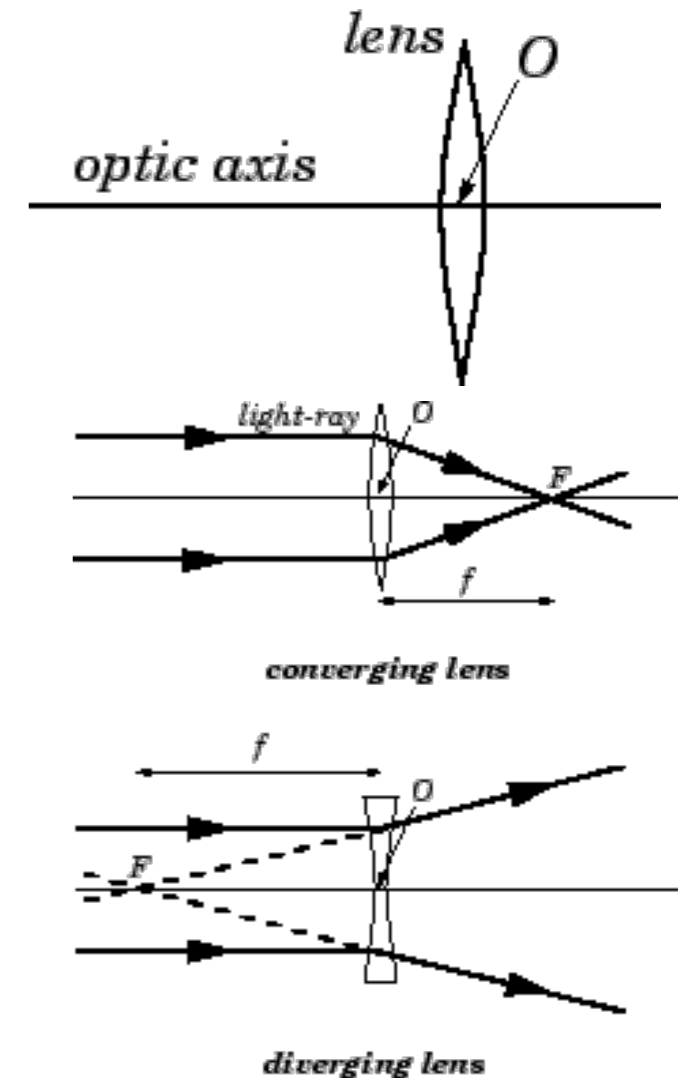

**Figure 1.14** A plane wave set-up



# Image Formation – Lenses

- A lens is a transparent medium bounded by two curved surfaces (spherical or cylindrical)
- Line passing normally through both bounding surfaces of a lens is called the optic axis.
- The point  $O$  on the optic axis midway between the two bounding surfaces is called the optic centre.
- There are 2 basic kinds: **converging**, **diverging**
- Converging lens - brings all incident light-rays parallel to its optic axis together at a point  $F$ , behind the lens, called the focal point, or focus.
- Diverging lens spreads out all incident light-rays parallel to its optic axis so that they appear to diverge from a virtual focal point  $F$  in front of the lens.
- Front side is conventionally to be the side from which the light is incident.



# Image Formation – Lenses

- Relationship between object and image distances to focal length is given by

$$\frac{1}{f} = \frac{1}{s} + \frac{1}{s''}$$

- Magnification of the lens is given by  $m = \frac{s''}{s} = \frac{h''}{h}$ .

- Example (Object outside Focal Point)**

- Object distance  $S = 200\text{mm}$  Object height  $h = 1\text{mm}$

- Focal length of the lens  $f = 50\text{mm}$

- Find image distance  $S'$  and Magnification  $m$

$$\frac{1}{s''} = \frac{1}{f} - \frac{1}{s}$$

$$\frac{1}{s''} = \frac{1}{50} - \frac{1}{200}$$

$$s'' = 66.7 \text{ mm}$$

$$m = \frac{s''}{s} = \frac{66.7}{200} = 0.33$$

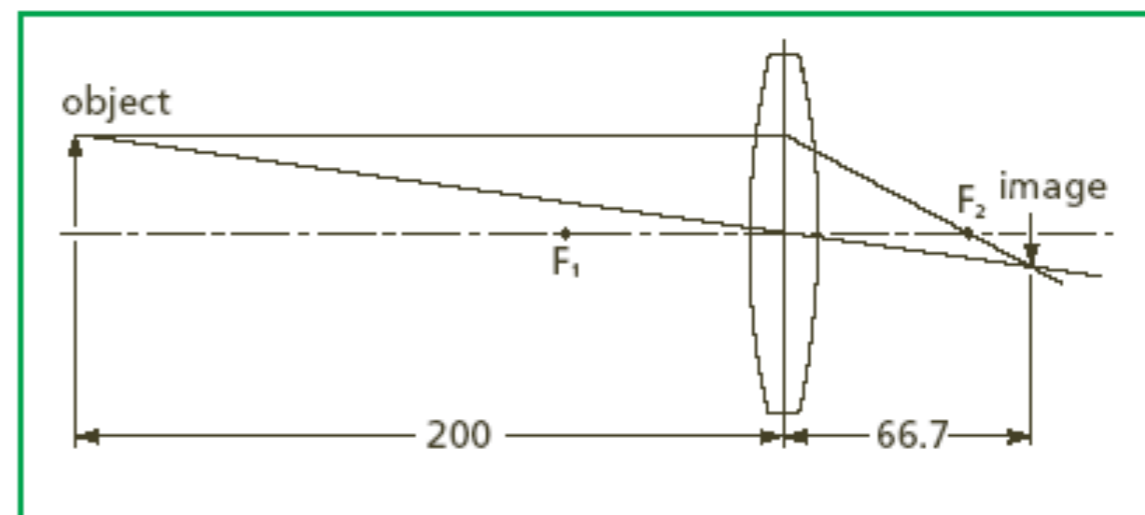

(or real image is 0.33 mm high and inverted).

# Image Formation – Lenses

- Relationship between object and image distances to focal length is given by

$$\frac{1}{f} = \frac{1}{s} + \frac{1}{s''}$$

- Magnification of the lens is given by

$$m = \frac{s''}{s} = \frac{h''}{h}$$

- Example (Object inside Focal Point)**

- Object distance  $S = 30\text{mm}$  Object height  $h = 1\text{mm}$
- Focal length of the lens  $f = 50\text{mm}$
- Find image distance  $S'$  and Magnification  $m$

$$\frac{1}{s''} = \frac{1}{50} - \frac{1}{30}$$

$$s'' = -75 \text{ mm}$$

$$m = \frac{s''}{s} = \frac{-75}{30} = -2.5$$

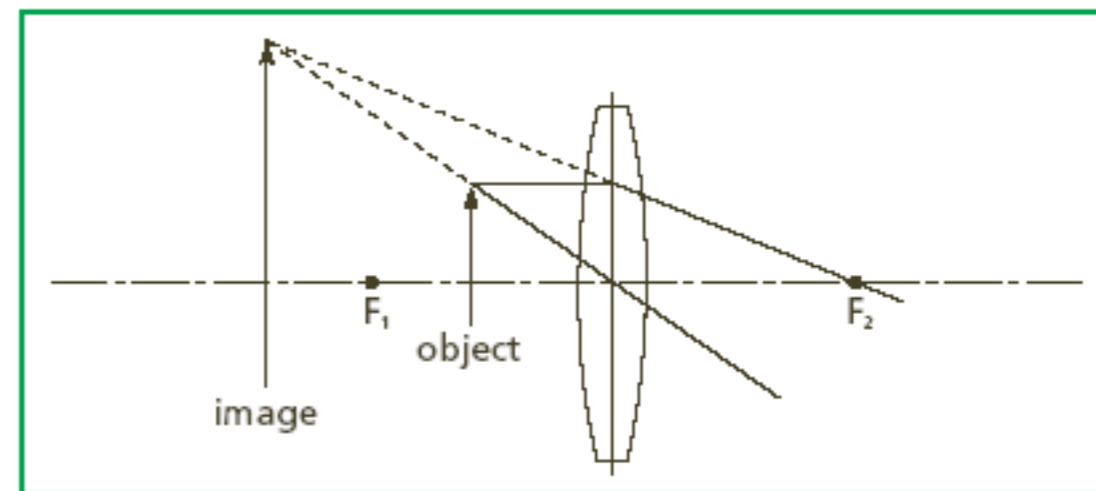

(or virtual image is 2.5 mm high and upright).

# Image Formation – Lenses

- Relationship between object and image distances to focal length is given by

$$\frac{1}{f} = \frac{1}{s} + \frac{1}{s''}$$

- Magnification of the lens is given by

$$m = \frac{s''}{s} = \frac{h''}{h}$$

- Example (Object at Focal Point)**

- Object distance  $S = 30\text{mm}$  Object height  $h = 1\text{mm}$
- Focal length of the lens  $f = -50\text{mm}$  (diverging lens)
- Find image distance  $S'$  and Magnification  $m$

$$\frac{1}{s''} = \frac{1}{-50} - \frac{1}{50}$$

$$s'' = -25 \text{ mm}$$

$$m = \frac{s''}{s} = \frac{-25}{50} = -0.5$$

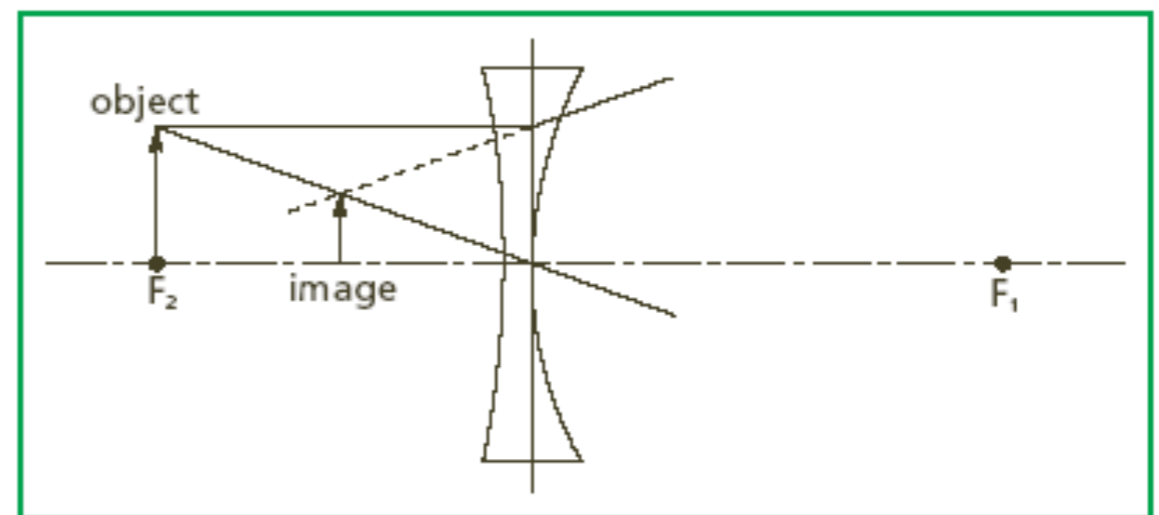

(or virtual image is 0.5 mm high and upright).

# F-Number and NA

- The calculations used to determine lens dia are based on the concepts of focal ratio (f-number) and numerical aperture (NA).
- The f-number is the ratio of the lens focal length of the to its clear aperture (effective diameter  $\phi$ ).

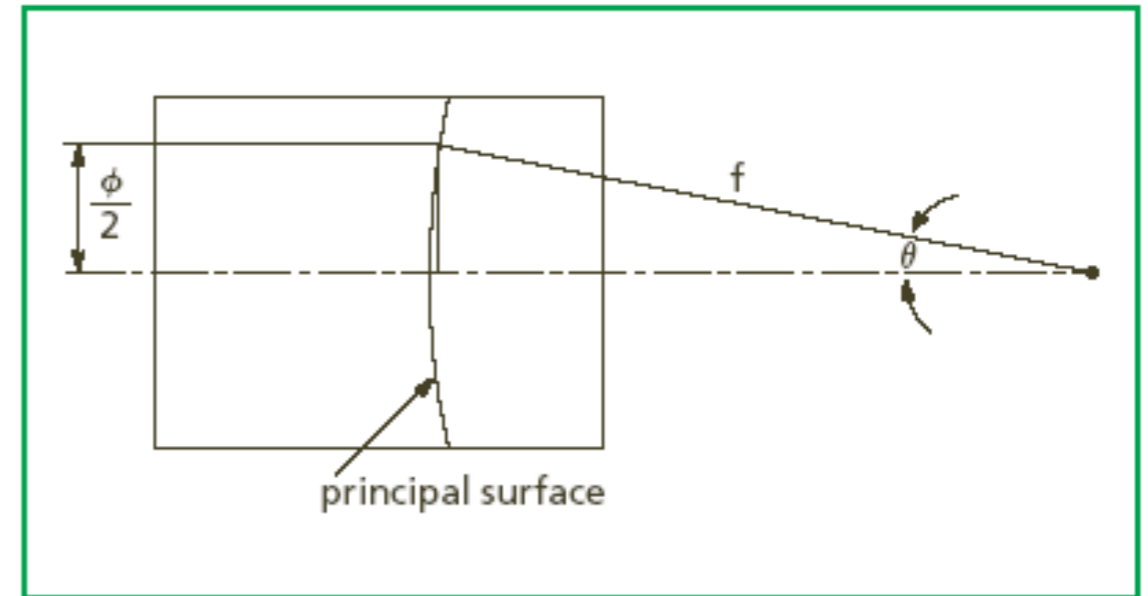

- The f-number defines the angle of the cone of light leaving the lens which ultimately forms the image.
- The other term used commonly in defining this cone angle is numerical aperture NA.
- NA is the sine of the angle made by the marginal ray with the optical axis. By using simple trigonometry, it can be seen that

$$\text{f-number} = \frac{f}{\phi}$$

$$\text{NA} = \sin\theta = \frac{\phi}{2f}$$

or

$$\text{NA} = \frac{1}{2(\text{f-number})}$$

# Spherical Aberration

- Spherical aberration comes from the spherical surface of a lens
- The further away the rays from the lens center, the bigger the error is
- Common in single lenses.
- The distance along the optical axis between the closest and farthest focal points is called (LSA)
- The height at which these rays is called (TSA)
- $TSA = LSA \times \tan u''$
- Spherical aberration is dependent on lens shape, orientation and index of refraction of the lens
- Aspherical lenses offer best solution, but difficult to manufacture
- So cemented doublets (+ve and -ve) are used to eliminate this aberration

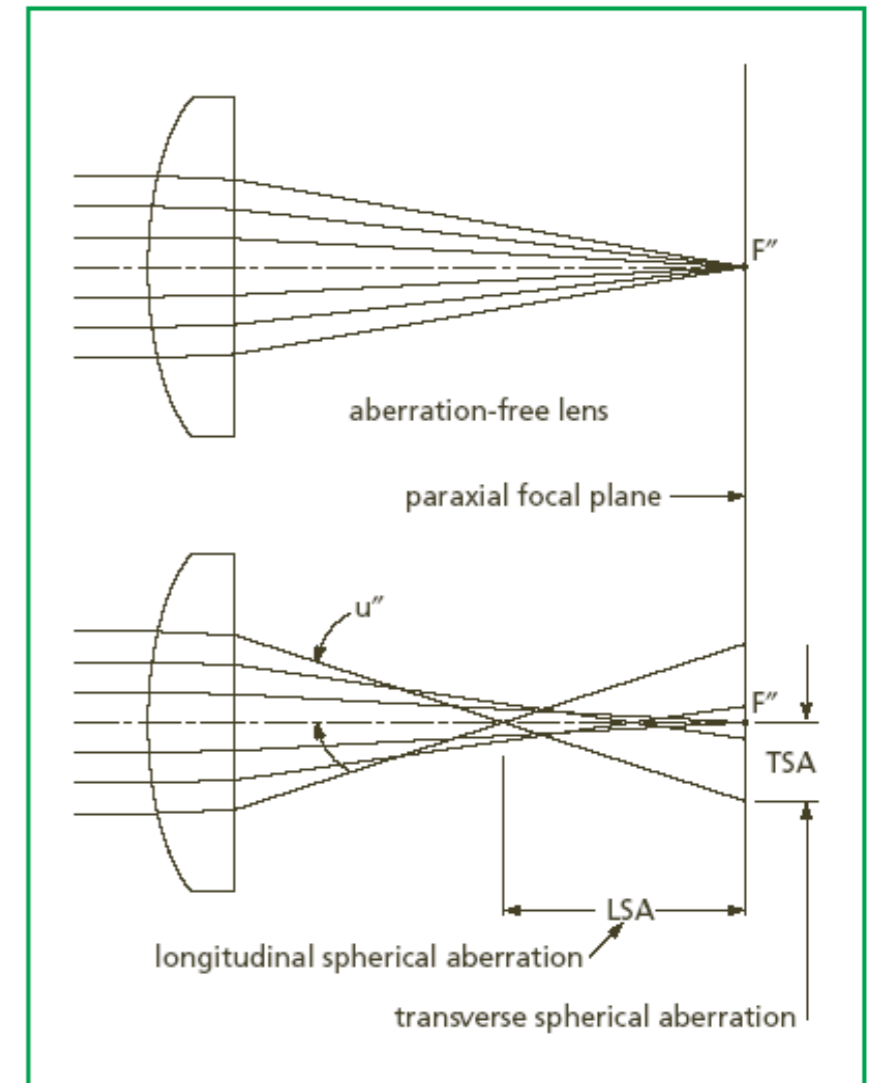
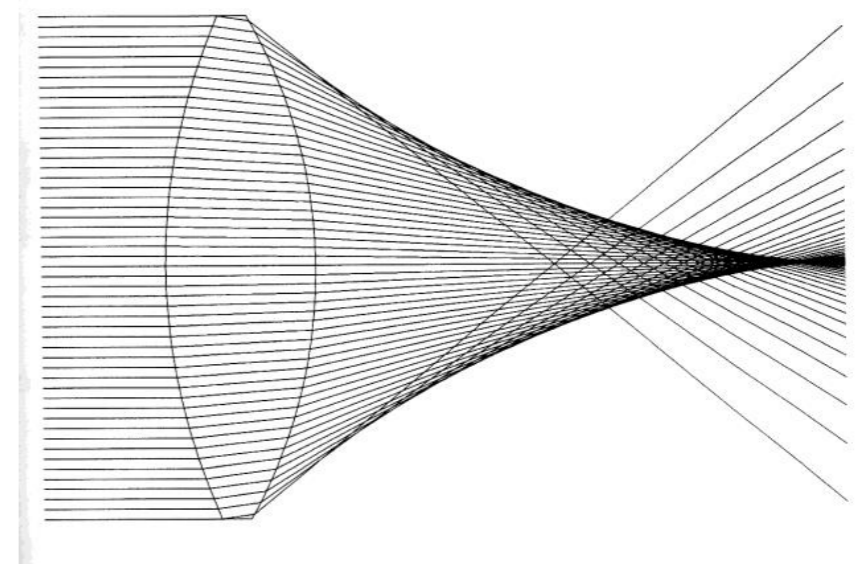

Spherical aberration of a plano-convex lens



# Astigmatism

- When an off-axis object is focused by a spherical lens, the natural asymmetry leads to astigmatism.
- The system appears to have two different focal lengths. Sagittal and tangential planes
- Between these conjugates, the image is either an elliptical or a circular blur. Astigmatism is defined as the separation of these conjugates.
- The amount of astigmatism depends on lens shape

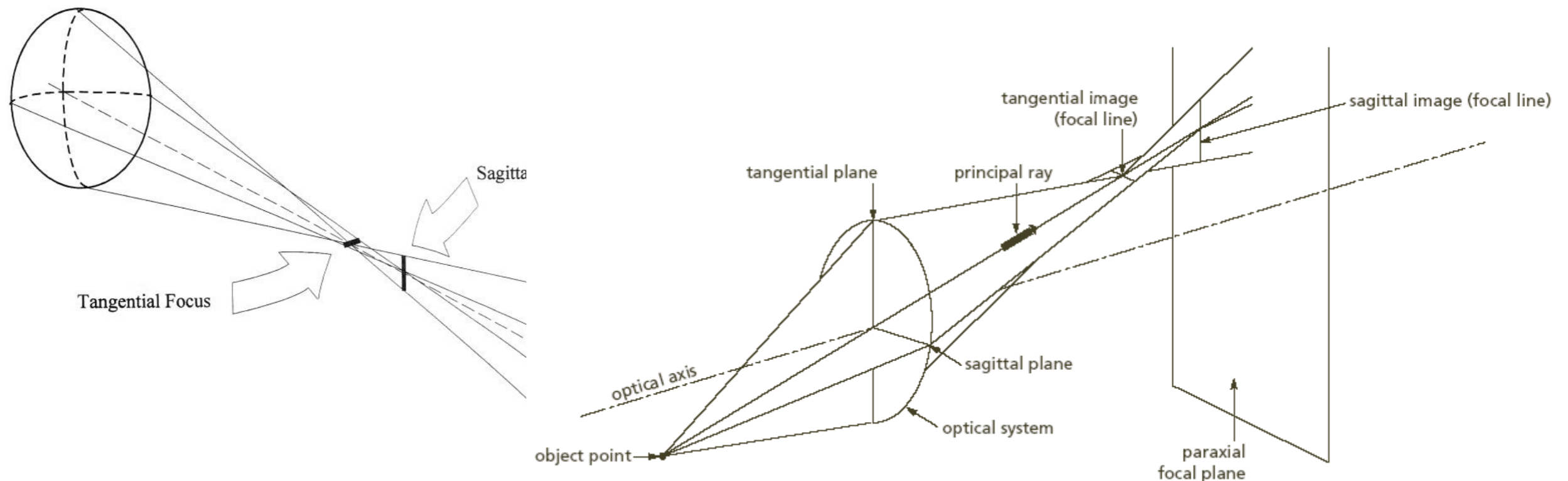

# Astigmatism

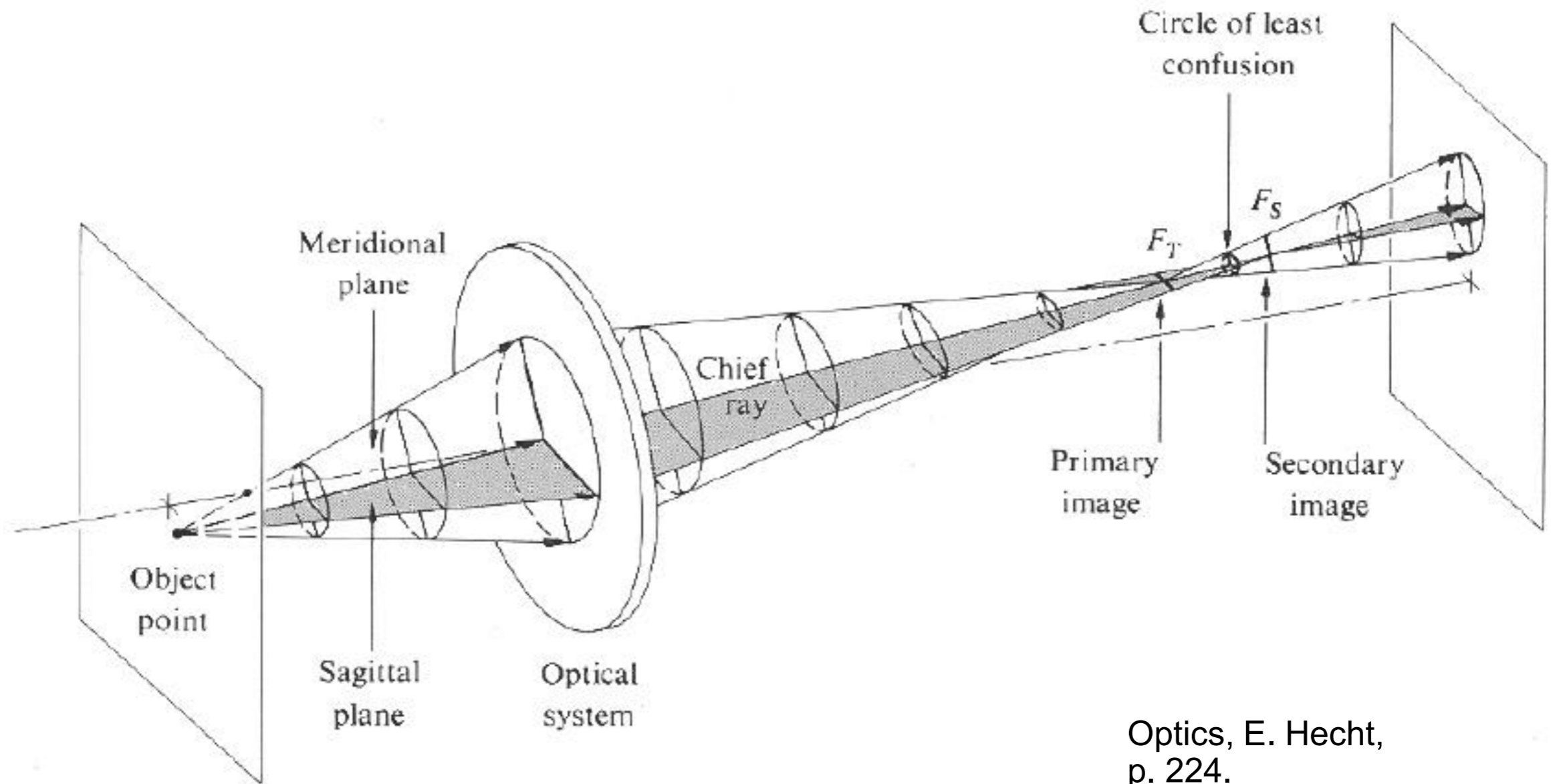

Optics, E. Hecht,  
p. 224.

# Astigmatism

Original

•  
aio

Compromise

•  
aio

Horizontal Focus

•  
aio

Vertical Focus

•  
aio

# Chromatic Aberration

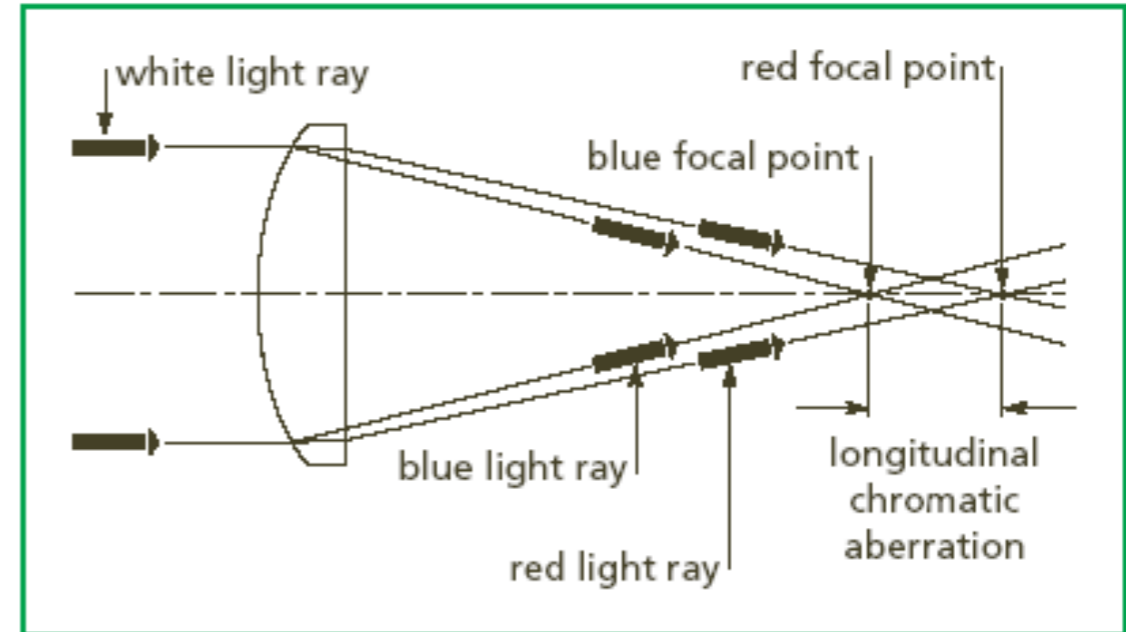
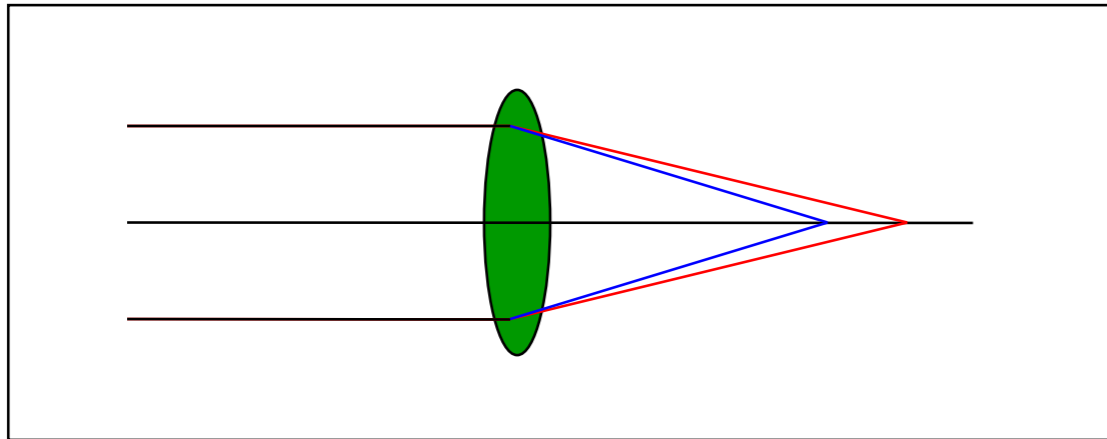

- Material usually have different refractive indices for different wavelengths  
 $n_{\text{blue}} > n_{\text{red}}$
- This is dispersion
- blue refracts more than the red, blue has a closer focus

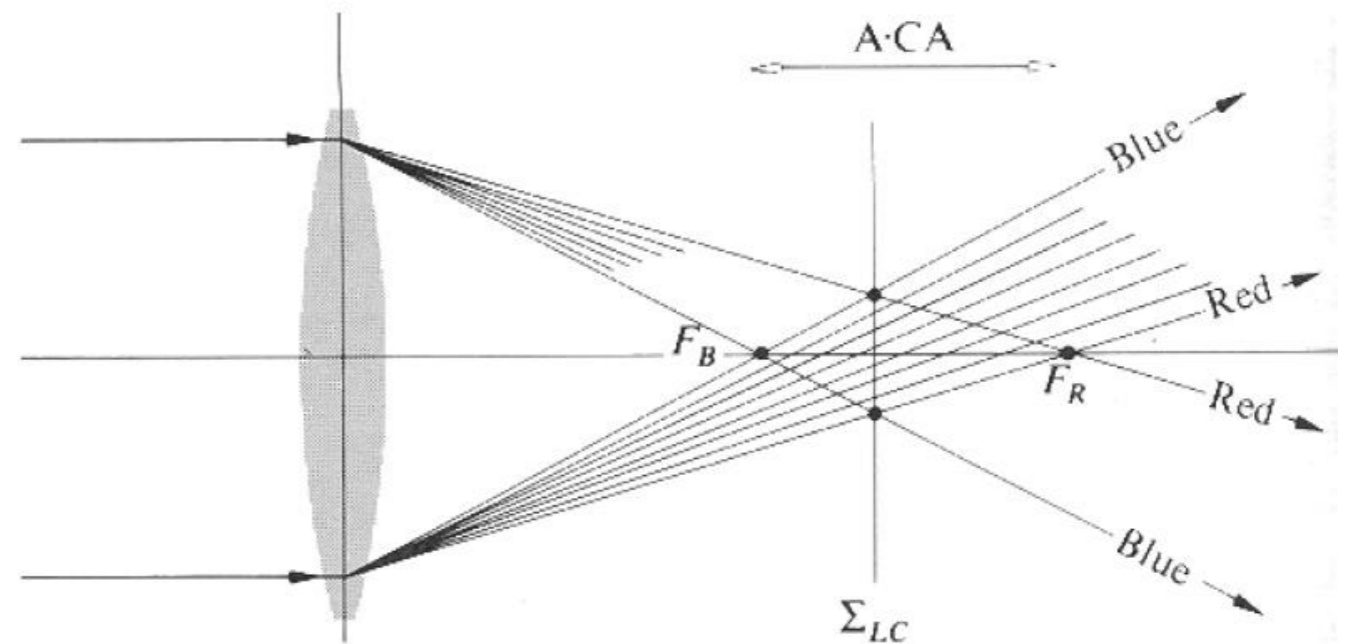

Figure 6.32 Axial chromatic aberration.